



Semester Long Internship Spring 2026

On

Integrated Circuit Design using Subcircuit feature of eSim

Submitted by

DIGAMBAR PRAKASH WAGHOLIKAR

Shri Guru Gobind Singhji Institute of Engineering and Technology
(SGGSIE&T)

Under the guidance of

Prof. Prabhu Ramachandran

Principal Investigator
Department of Aerospace Engineering
Indian Institute of Technology Bombay

9 may 2026

Acknowledgment

I express my sincere gratitude to Prof. Prabhu Ramachandran for providing me with the opportunity to be part of the FOSSEE internship program and for his continued efforts in promoting open-source engineering tool development. His leadership and vision have been instrumental in fostering meaningful student participation in the open-source ecosystem.

I also acknowledge Prof. Kannan M. Moudgalya for his foundational role in establishing and strengthening the FOSSEE initiative. His contributions to open-source education and the development of the FOSSEE fellowship framework have been pivotal in creating the academic and organisational platform through which this internship was undertaken.

My sincere appreciation extends to my mentor, Sumanto Kar, for his continual support, technical guidance, and encouragement throughout the duration of this project. His insights and feedback played a key role in refining ideas, overcoming challenges, and ensuring timely completion of the tasks assigned to me.

I would also like to thank my internal mentors, Mr. Varad Patil and Ms. Shanthi Priya K for their valuable guidance, coordination, and technical inputs during the internship. Their mentorship contributed significantly to the clarity, progress, and successful execution of the work.

This internship has been an enriching learning experience, allowing me to work closely with open-source EDA tools, develop IC subcircuits in eSim, and gain exposure to real-world circuit modeling and simulation workflows. The knowledge acquired during this period will undoubtedly support my future academic and professional pursuits.

I would also like to thank the entire FOSSEE team for their coordination, assistance, and timely interactions at various stages of this work. Their collective efforts ensured smooth workflow, resource accessibility, and effective project execution.

Contents

Acknowledgment	1
1 Introduction	4
1.1 eSim	4
1.2 Ngspice	4
1.3 KiCad	4
1.4 GHDL	4
2 Features of eSim	5
3 Problem Statement	7
3.1 Approach	7
4 Integrated Circuit Design	8
4.1 SN74HC158 - Quadruple 2-Line to 1-Line Data Selectors/Multiplexers	8
4.1.1 Pin Diagram	9
4.1.2 Subcircuit Schematic Diagram	10
4.1.3 Test Circuit	10
4.1.4 Waveforms	11
4.2 SN74LS139 - Dual 2-to-4 Line Decoder	11
4.2.1 Pin Diagram	12
4.2.2 Subcircuit Schematic Diagram	13
4.2.3 Test Circuit	13
4.2.4 Waveforms	14
4.3 MM74HC133 - 13-Input NAND Gate	14
4.3.1 Pin Diagram	15
4.3.2 Subcircuit Schematic Diagram	16
4.3.3 Test Circuit	16
4.3.4 Waveforms	17
4.4 SNx4HC10 - Triple 3-Input NAND Gates	17
4.4.1 Pin Diagram	18
4.4.2 Subcircuit Schematic Diagram	19
4.4.3 Test Circuit	19
4.4.4 Waveforms	20
4.5 74HCT280 - 9-Bit Odd/Even Parity Generator Checker	20
4.5.1 Pin Diagram	21
4.5.2 Subcircuit Schematic Diagram	22

4.5.3	Test Circuit	22
4.5.4	Waveforms	23
4.6	SNx4HC86 - Quadruple 2-Input Exclusive-OR Gates	23
4.6.1	Pin Diagram	24
4.6.2	Subcircuit Schematic Diagram	25
4.6.3	Test Circuit	25
4.6.4	Waveforms	26
4.7	HD74HC51 - AND-OR-INVERT Gate	26
4.7.1	Pin Diagram	27
4.7.2	Subcircuit Schematic Diagram	28
4.7.3	Test Circuit	28
4.7.4	Waveforms	29
5	Conclusion and Future Scope	30
6	References	31

Chapter 1

Introduction

1.1 eSim

eSim is an open-source Electronic Design Automation tool developed under the FOSSEE project at IIT Bombay. It provides an integrated environment for schematic design, simulation, PCB layout, and digital circuit analysis. The software combines several open-source tools into a single platform for electronic system design. It is widely used for educational and research purposes in electronics engineering.

1.2 Ngspice

Ngspice is an open-source mixed-signal circuit simulator based on the SPICE simulation engine. It is capable of performing DC, AC, transient, and noise analysis for analog and digital circuits. Ngspice plays a major role in verifying circuit functionality and waveform analysis in eSim. It is widely used for accurate electronic circuit simulation and testing.

1.3 KiCad

KiCad is an open-source EDA software suite used for schematic capture and PCB design. It provides tools for creating professional circuit schematics and multilayer PCB layouts. KiCad supports a wide range of component libraries and design rule checking features. In eSim, KiCad is integrated for designing and simulating electronic circuits efficiently.

1.4 GHDL

GHDL is an open-source VHDL simulator used for digital hardware design and verification. It allows users to compile, analyze, and simulate VHDL code for digital systems. GHDL helps in understanding the behavior of sequential and combinational logic circuits. It is useful in digital electronics education and hardware modeling applications.

Chapter 2

Features of eSim

The main objective of eSim is to provide a free and open-source platform for electronics design and simulation. It integrates various EDA tools into a single user-friendly environment. eSim supports both analog and digital circuit simulations for educational and research applications. The software encourages open-source development and collaborative learning.

1. Schematic Creation

eSim provides a graphical interface for creating electronic circuit schematics. Components can be selected from libraries and connected easily using wires and buses. The software supports editing, labeling, and organizing circuit designs efficiently. This feature simplifies circuit creation for beginners and professionals.

2. Circuit Simulation

eSim supports SPICE-based circuit simulation using Ngspice. Users can perform transient, DC, and AC analysis to study circuit behavior. Waveforms and output graphs can be generated for verification purposes. This helps in debugging and validating circuit performance before implementation.

3. PCB Design

eSim integrates KiCad for PCB design and layout generation. Components can be placed on PCB boards and traces can be routed accurately. The software supports design rule checking and Gerber file generation. This feature enables users to convert schematics into practical PCB layouts.

4. Subcircuit Feature

The subcircuit feature allows modular circuit design by reusing smaller circuit blocks. Users can create complex digital IC models using available device models in eSim. This feature improves design organization and reduces repetitive work. It is highly useful for hierarchical circuit development.

5. Open Source Integration

eSim integrates open-source tools such as KiCad, Ngspice, and GHDL into a unified platform. Being open-source, the software is freely accessible to students and researchers. It supports collaborative development and customization according to user requirements. This makes advanced EDA tools available without licensing costs.

Chapter 3

Problem Statement

The objective of this internship project is to design and develop various Digital Integrated Circuit models using the subcircuit feature available in eSim. These ICs are created using device model files already present in the eSim library. The developed subcircuits are intended for future integration into the eSim subcircuit library. The project mainly focuses on digital logic IC implementation and verification through simulation.

3.1 Approach

The project work started with studying datasheets from manufacturers such as Texas Instruments and ON Semiconductor. Suitable ICs were selected based on their functionality and practical applications in digital electronics. Each IC was implemented using available subcircuit models and verified through simulation in eSim. Waveform analysis and truth table verification were performed to ensure proper circuit operation.

Chapter 4

Integrated Circuit Design

4.1 SN74HC158 - Quadruple 2-Line to 1-Line Data Selectors/Multiplexers

The SN74HC158 is a quadruple 2-line to 1-line multiplexer IC used for selecting one output from multiple data inputs.

4.1.1 Pin Diagram

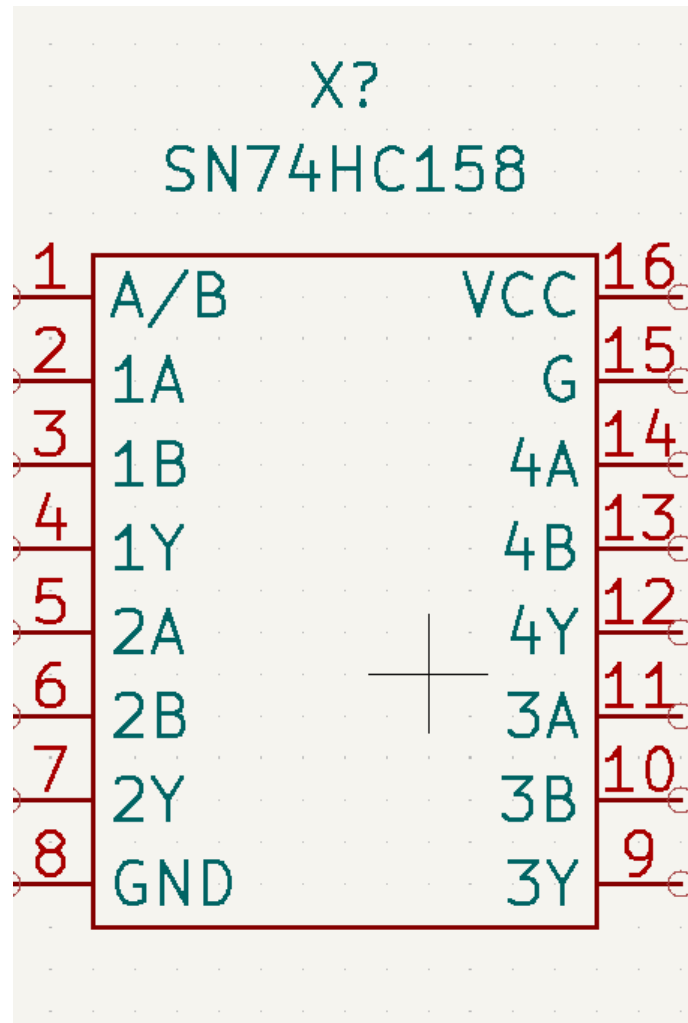

Figure 4.1: Pin Diagram of SN74HC158

4.1.2 Subcircuit Schematic Diagram

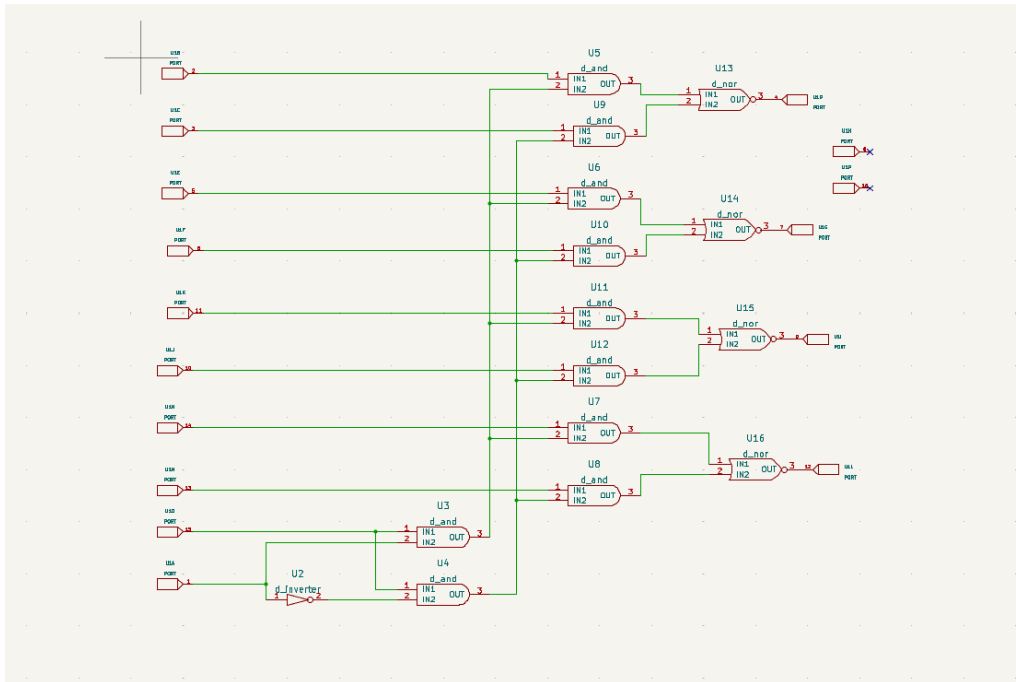

Figure 4.2: Subcircuit Schematic of SN74HC158

4.1.3 Test Circuit

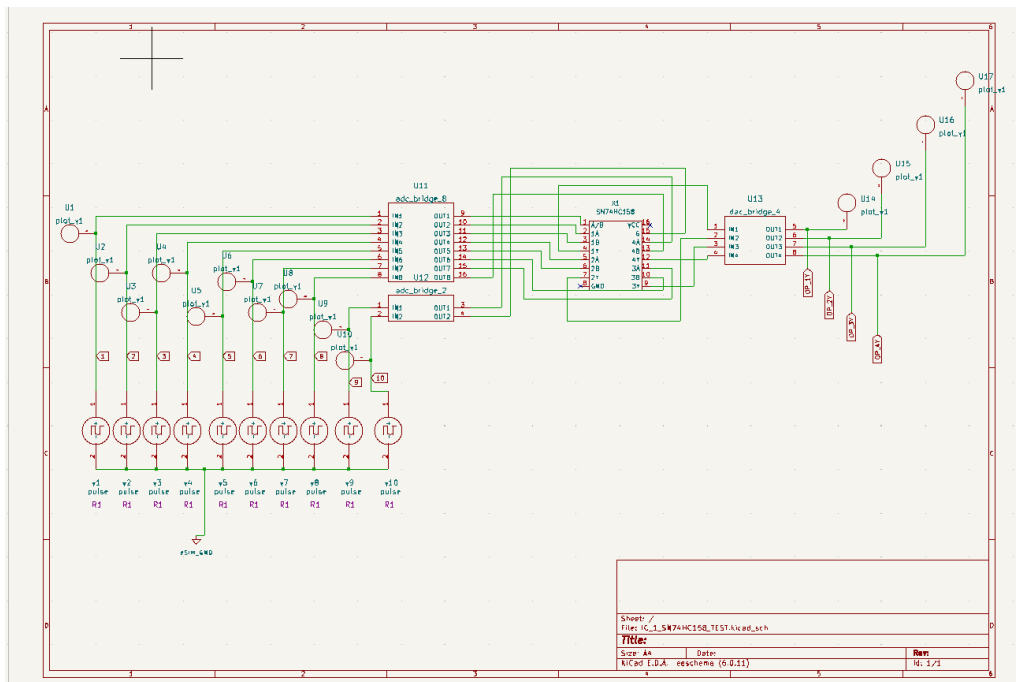

Figure 4.3: Test Circuit of SN74HC158

4.1.4 Waveforms

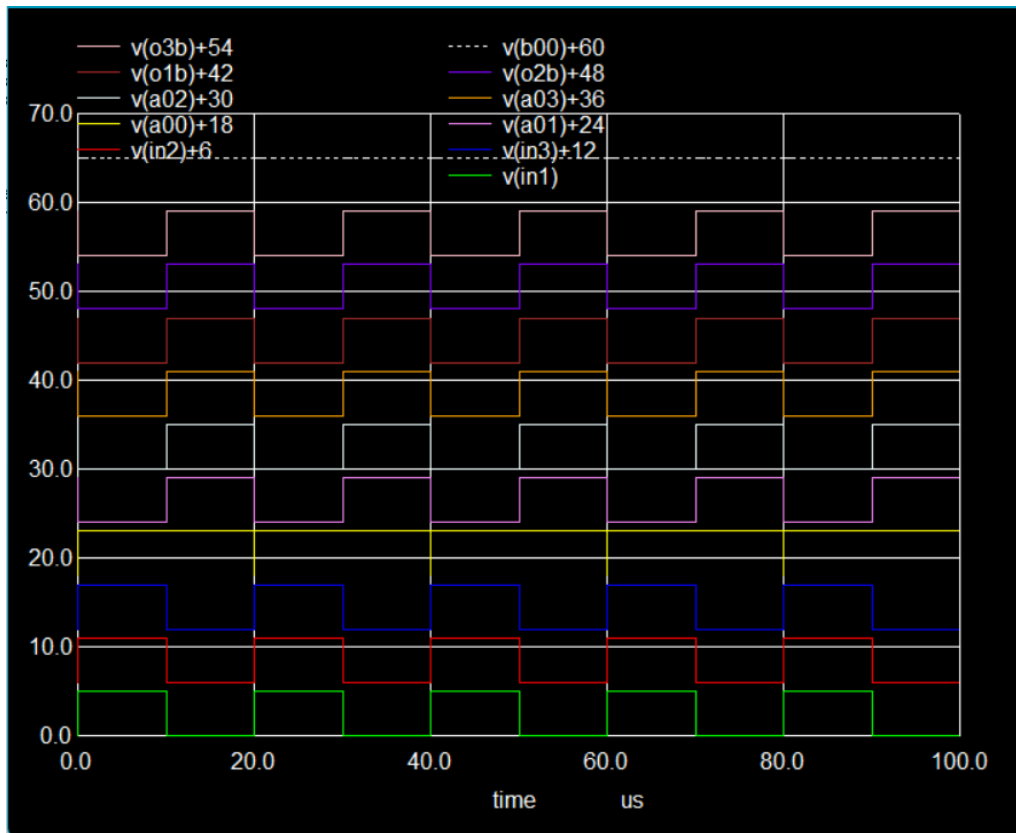

Figure 4.4: Waveform Output of SN74HC158

4.2 SN74LS139 - Dual 2-to-4 Line Decoder

The SN74LS139 is a dual 2-to-4 line decoder IC used for memory decoding applications.

4.2.1 Pin Diagram

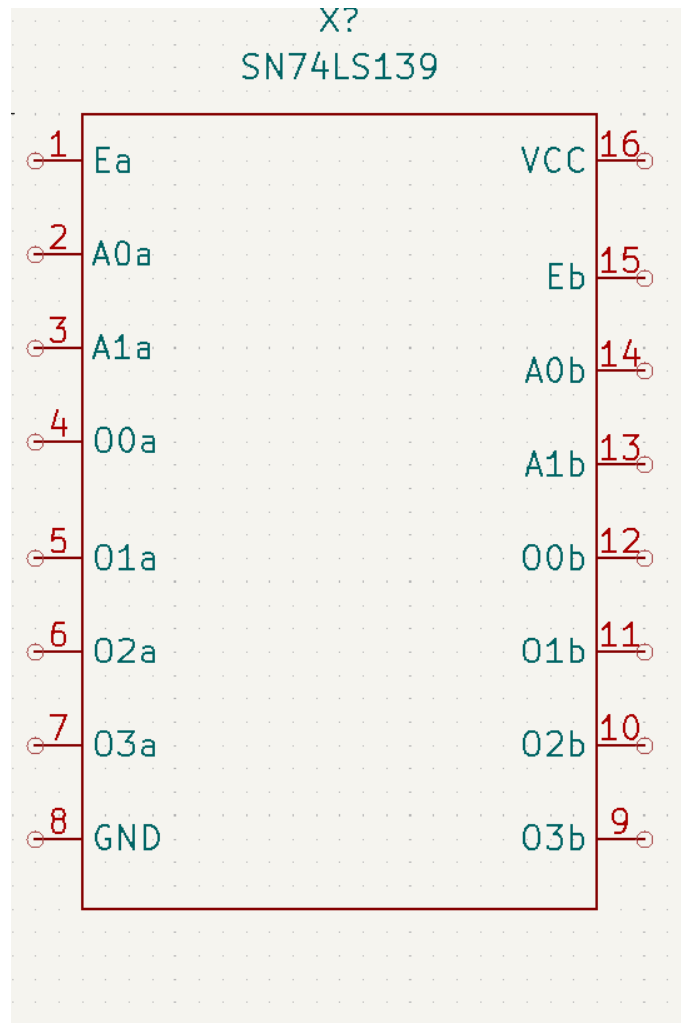

Figure 4.5: Pin Diagram of SN74LS139

4.2.2 Subcircuit Schematic Diagram

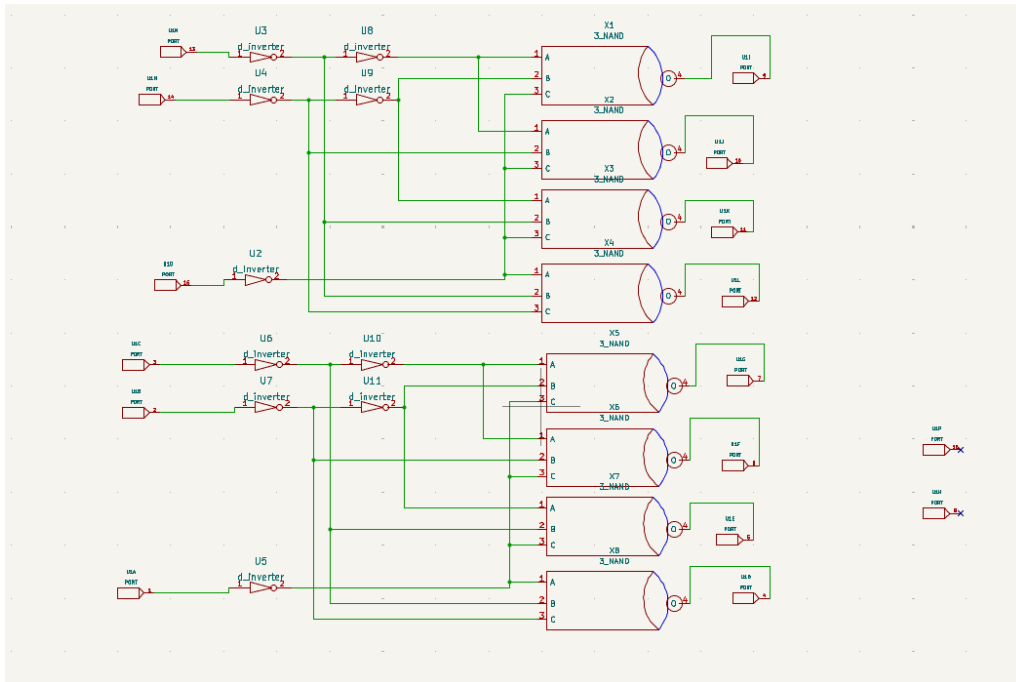

Figure 4.6: Subcircuit Schematic of SN74LS139

4.2.3 Test Circuit

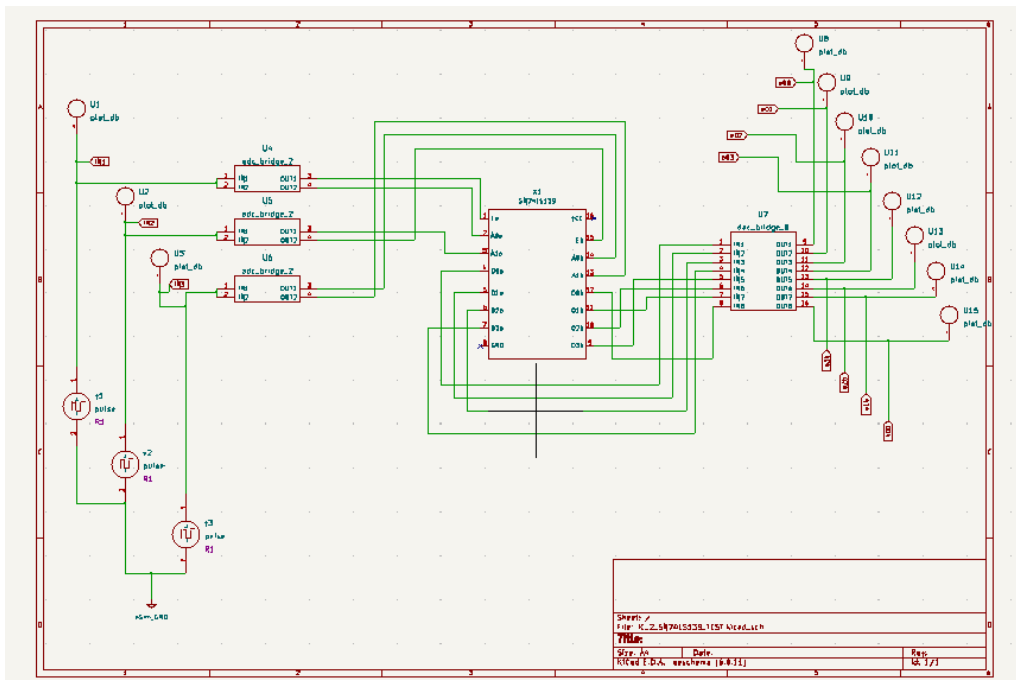

Figure 4.7: Test Circuit of SN74LS139

4.2.4 Waveforms

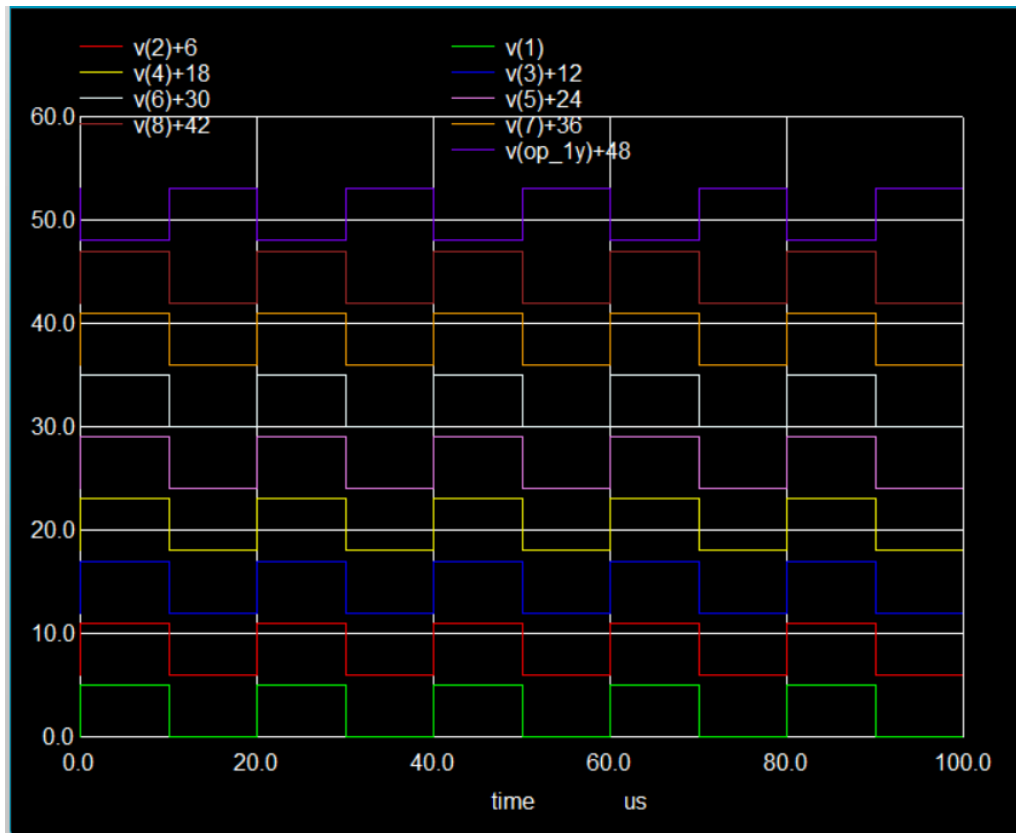

Figure 4.8: Waveform Output of SN74LS139

4.3 MM74HC133 - 13-Input NAND Gate

The MM74HC133 is a high-speed 13-input NAND gate IC used in complex digital logic applications.

4.3.1 Pin Diagram

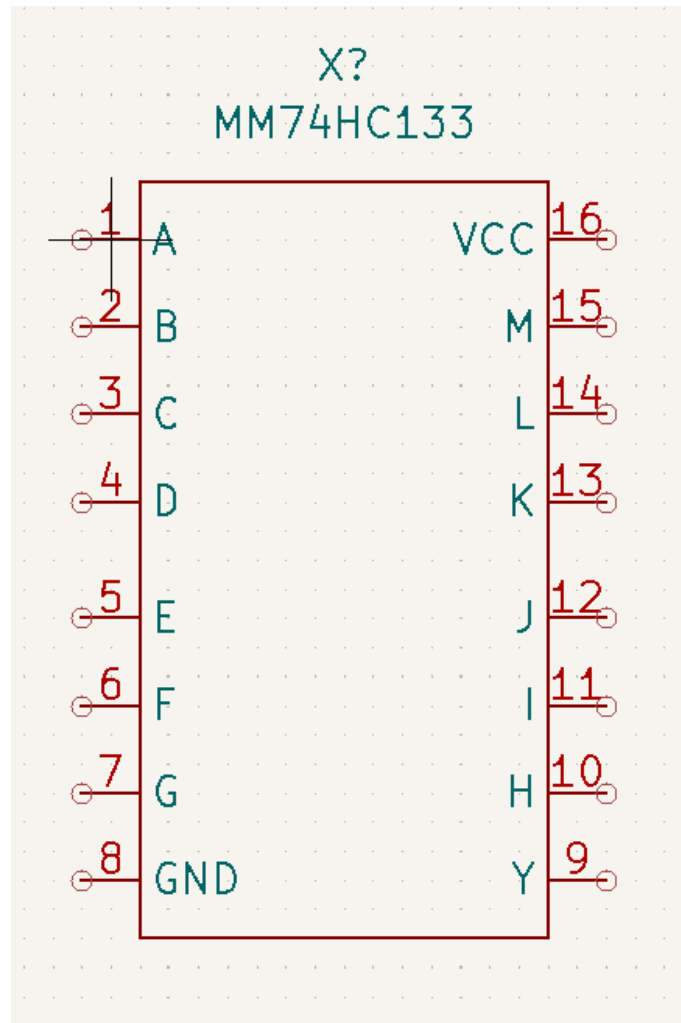

Figure 4.9: Pin Diagram of MM74HC133

4.3.2 Subcircuit Schematic Diagram

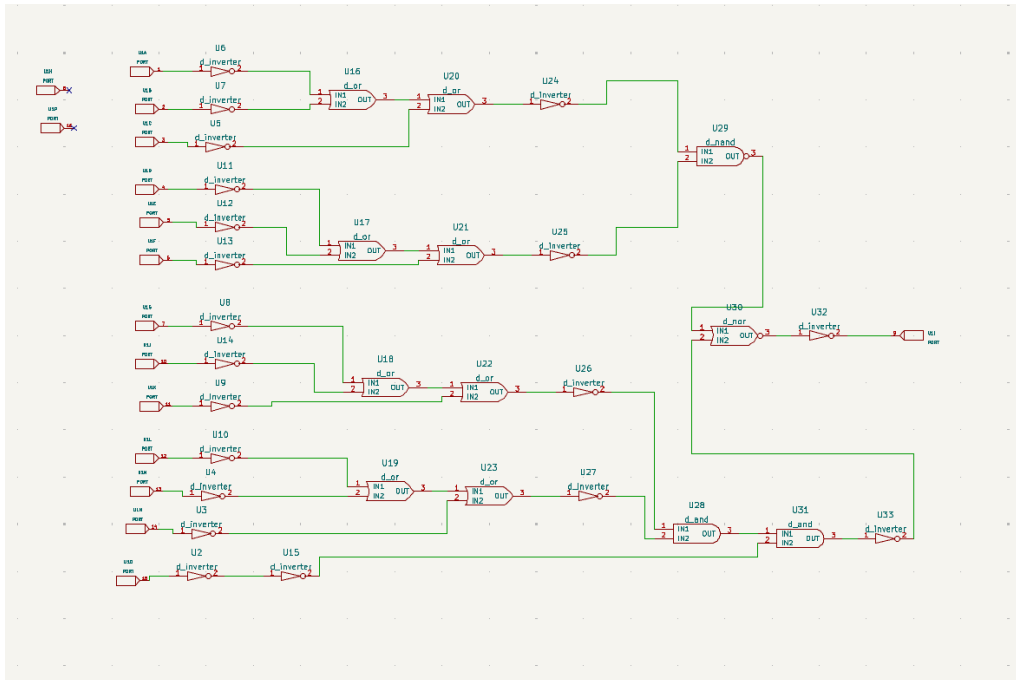

Figure 4.10: Subcircuit Schematic of MM74HC133

4.3.3 Test Circuit

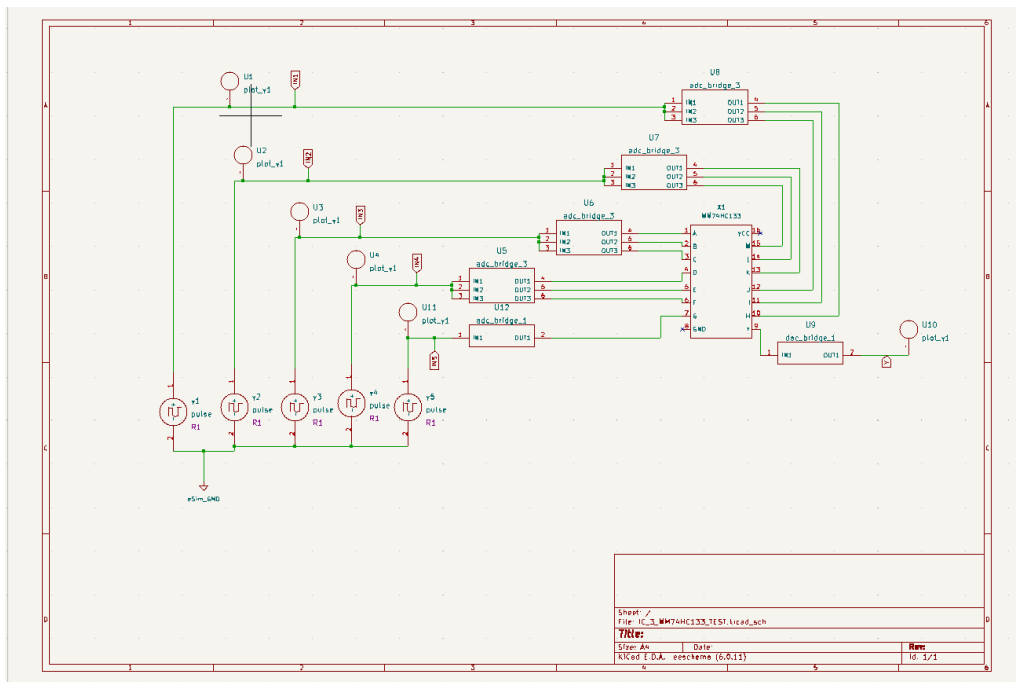

Figure 4.11: Test Circuit of MM74HC133

4.3.4 Waveforms

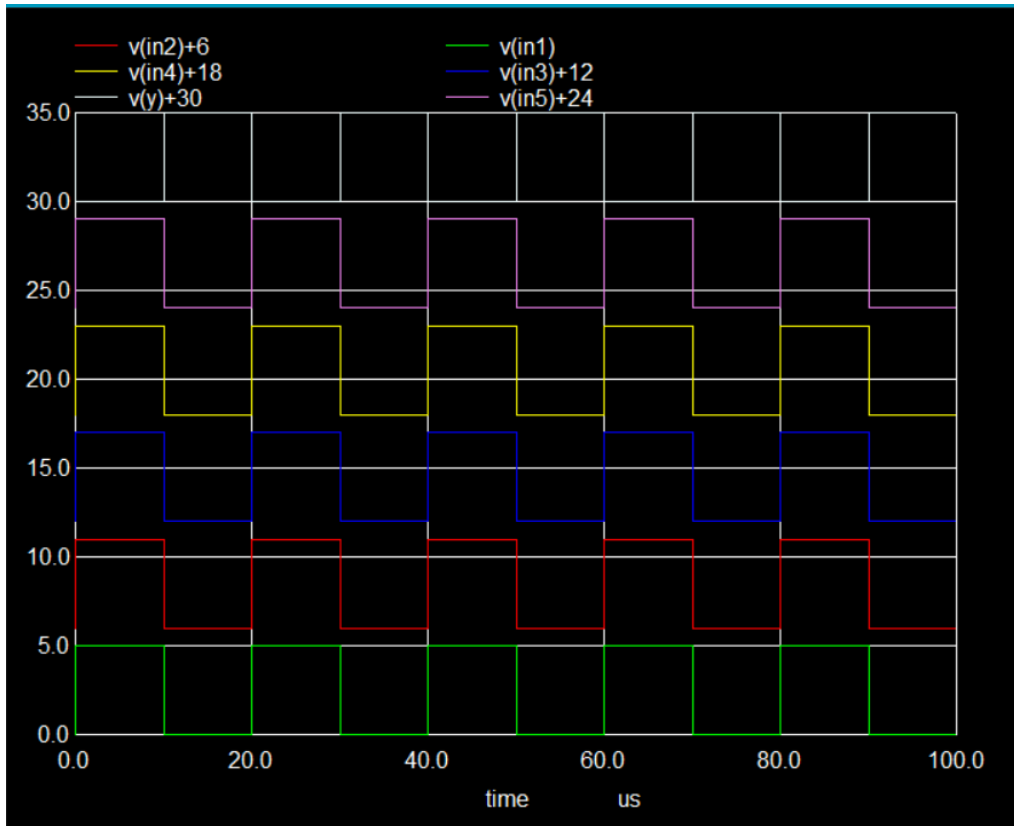

Figure 4.12: Waveform Output of MM74HC133

4.4 SNx4HC10 - Triple 3-Input NAND Gates

The SNx4HC10 IC consists of triple 3-input NAND gates designed for digital logic operations.

4.4.1 Pin Diagram

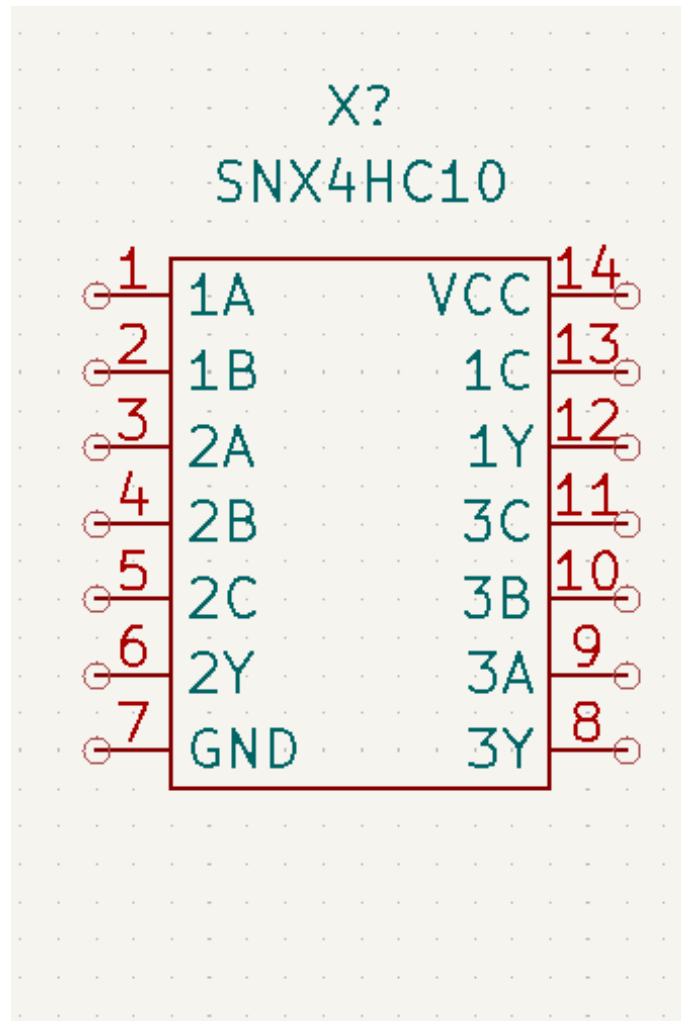

Figure 4.13: Pin Diagram of SNx4HC10

4.4.2 Subcircuit Schematic Diagram

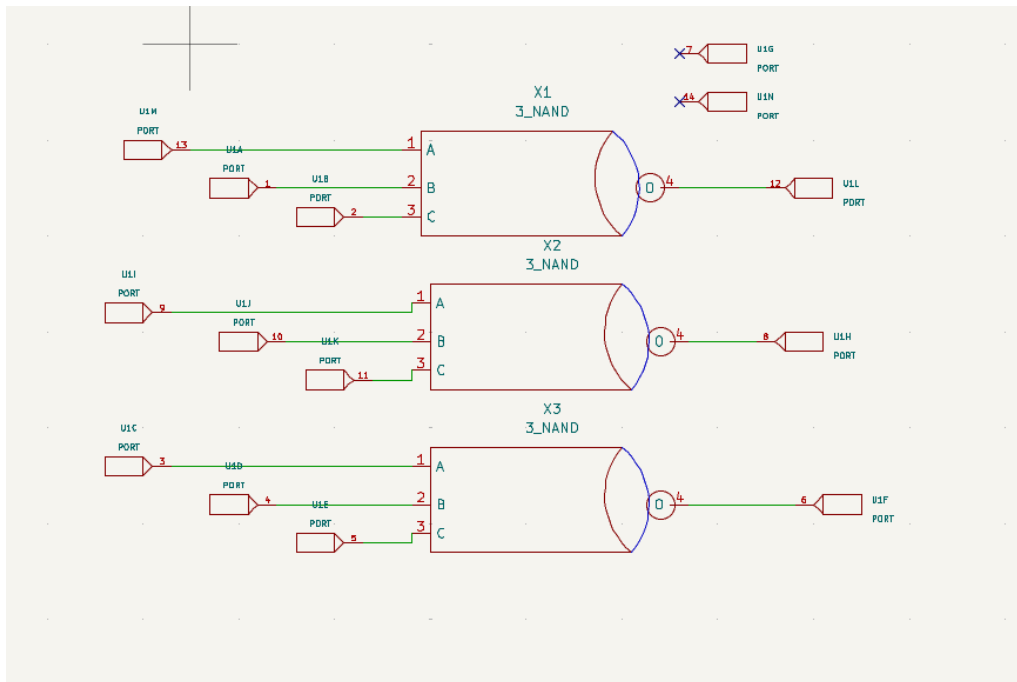

Figure 4.14: Subcircuit Schematic of SNx4HC10

4.4.3 Test Circuit

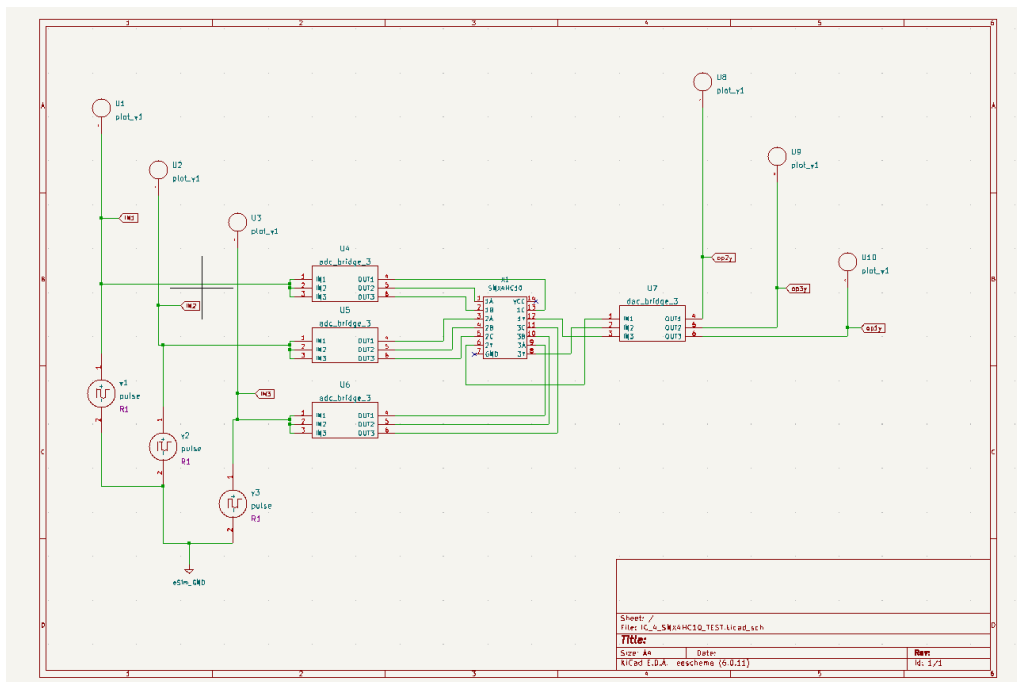

Figure 4.15: Test Circuit of SNx4HC10

4.4.4 Waveforms

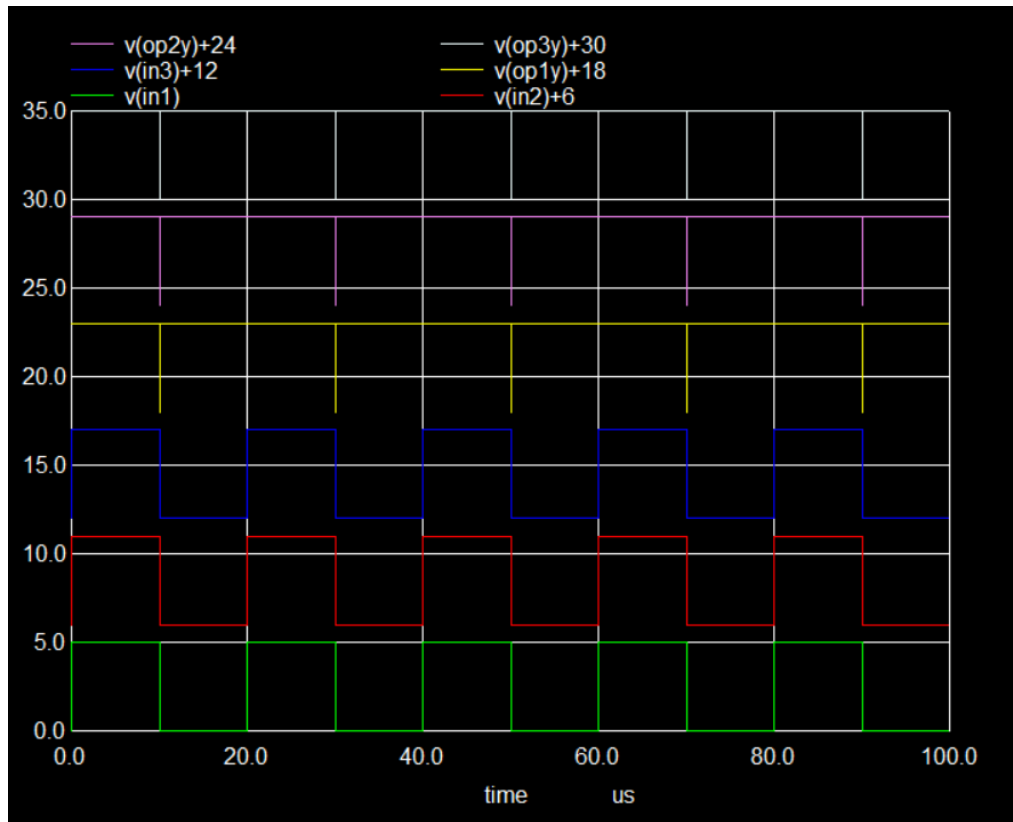

Figure 4.16: Waveform Output of SNx4HC10

4.5 74HCT280 - 9-Bit Odd/Even Parity Generator Checker

The 74HCT280 is a parity generator and checker IC used in error detection systems.

4.5.1 Pin Diagram

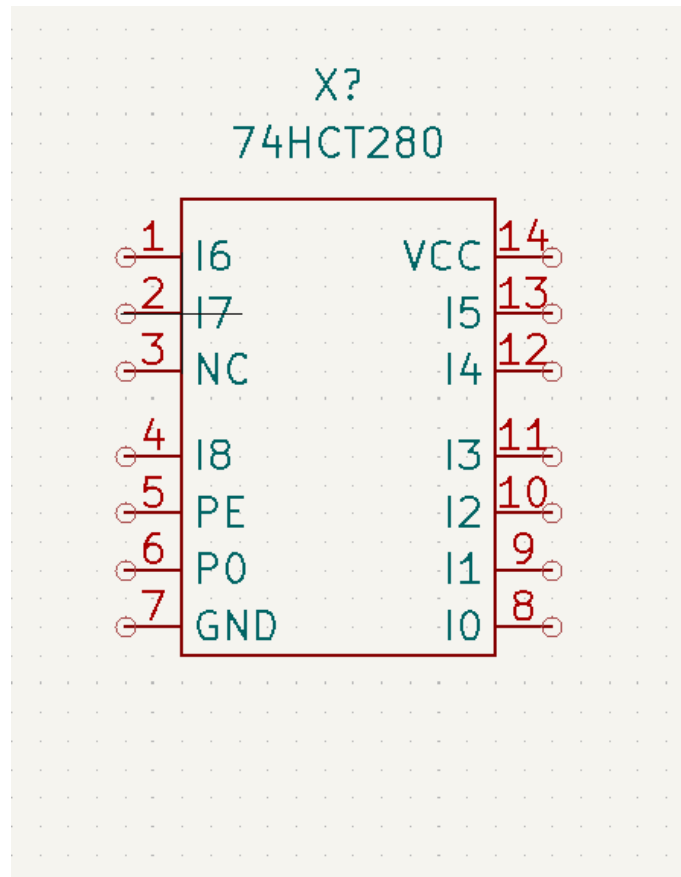

Figure 4.17: Pin Diagram of 74HCT280

4.5.2 Subcircuit Schematic Diagram

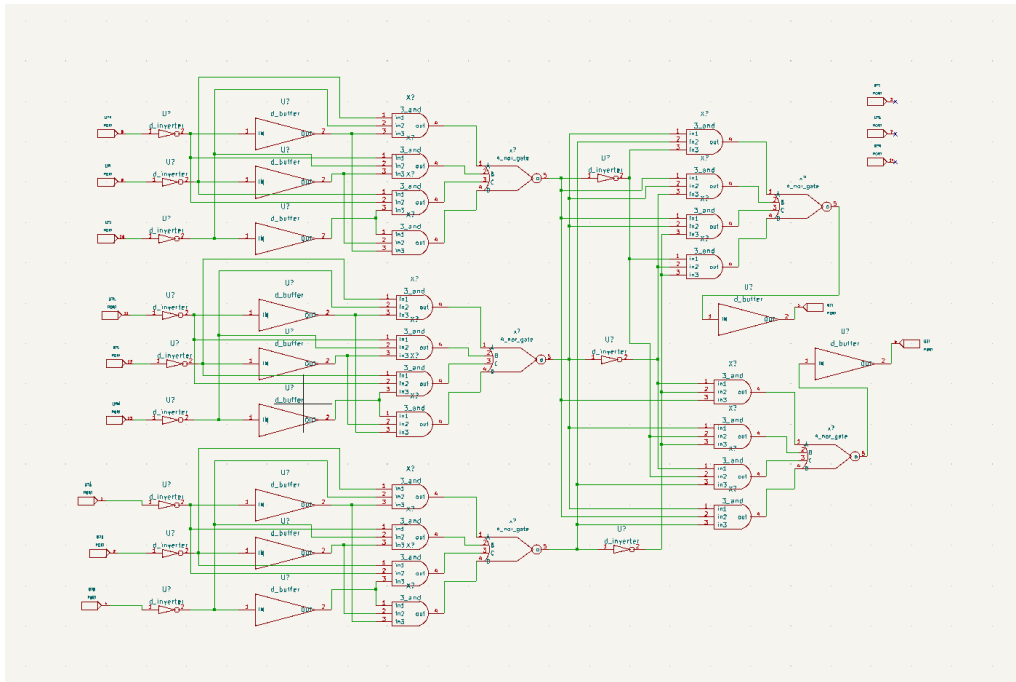

Figure 4.18: Subcircuit Schematic of 74HCT280

4.5.3 Test Circuit

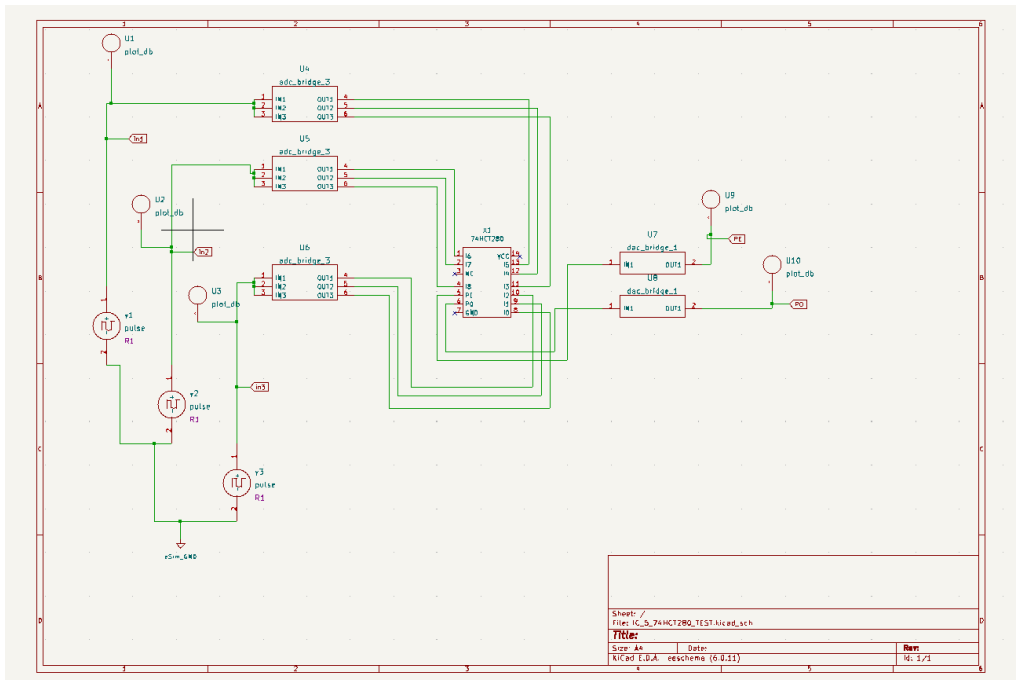

Figure 4.19: Test Circuit of 74HCT280

4.5.4 Waveforms

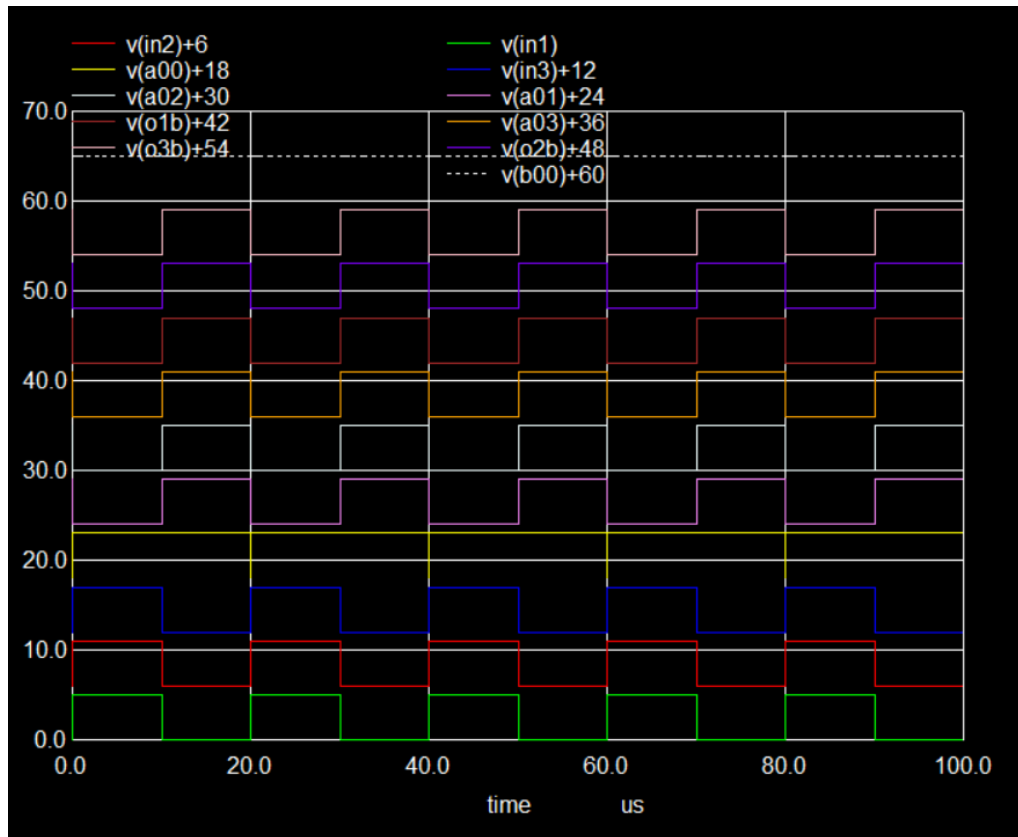

Figure 4.20: Waveform Output of 74HCT280

4.6 SNx4HC86 - Quadruple 2-Input Exclusive-OR Gates

The SNx4HC86 is a quadruple 2-input XOR gate IC widely used in digital electronics.

4.6.1 Pin Diagram

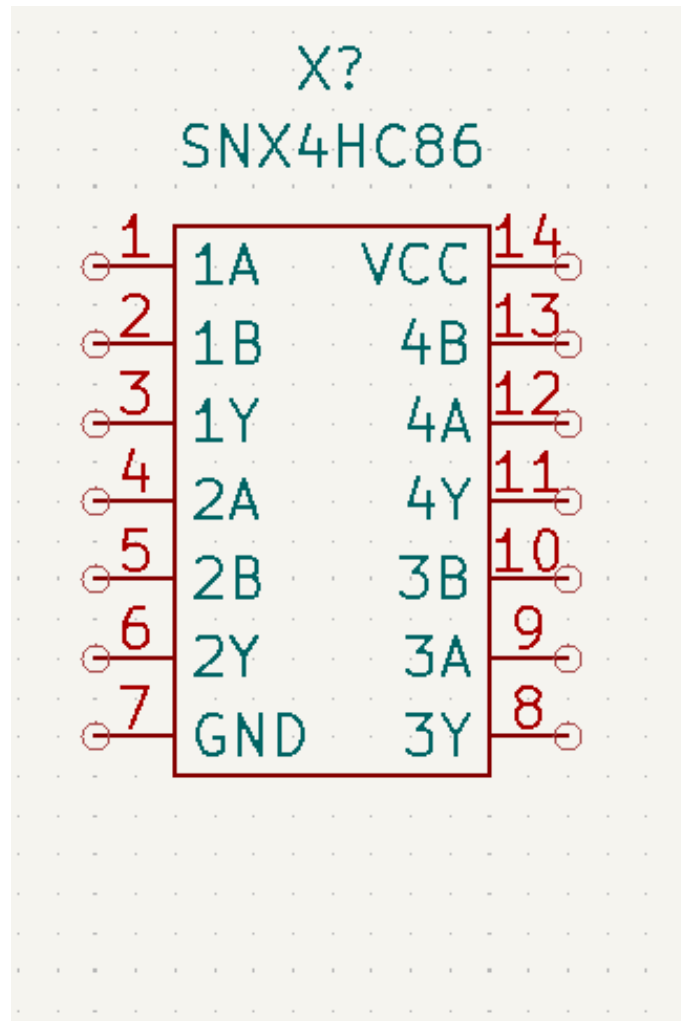

Figure 4.21: Pin Diagram of SNx4HC86

4.6.2 Subcircuit Schematic Diagram

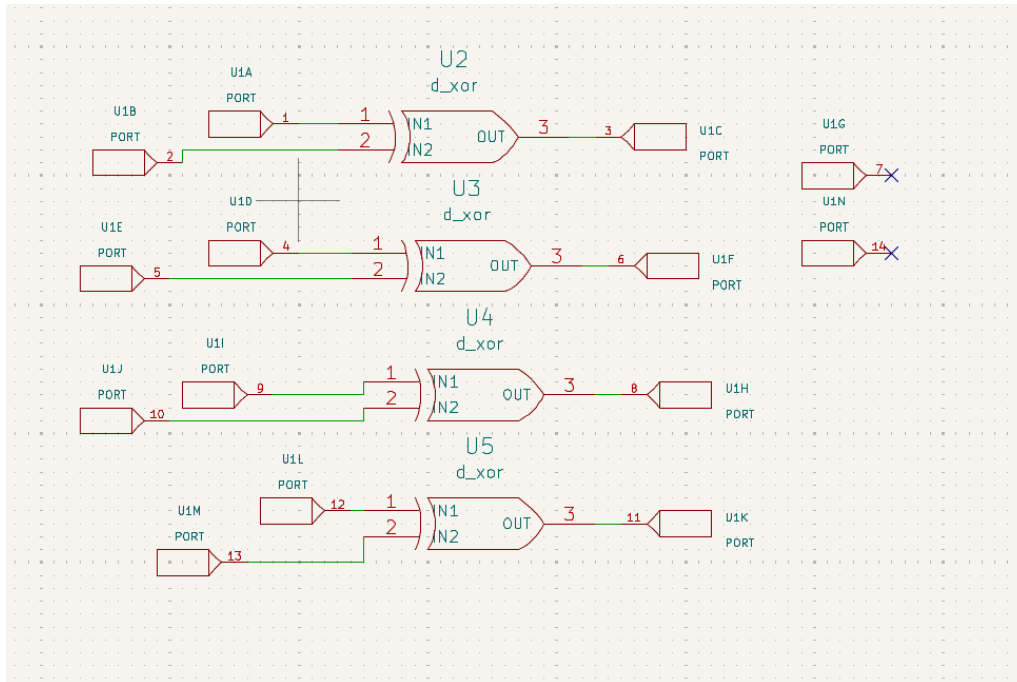

Figure 4.22: Subcircuit Schematic of SNx4HC86

4.6.3 Test Circuit

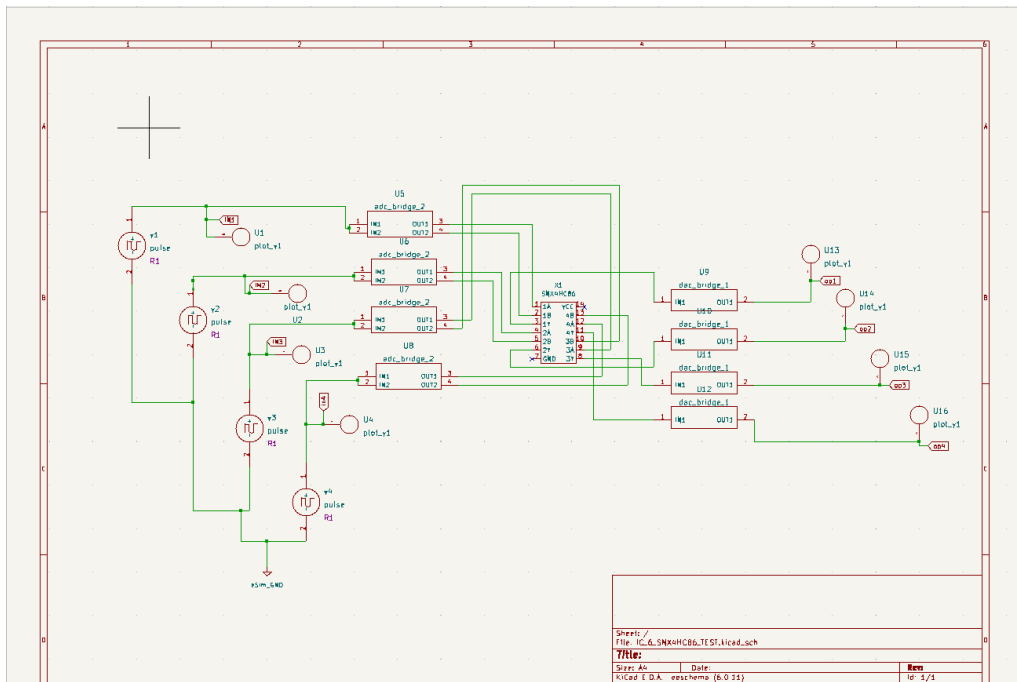

Figure 4.23: Test Circuit of SNx4HC86

4.6.4 Waveforms

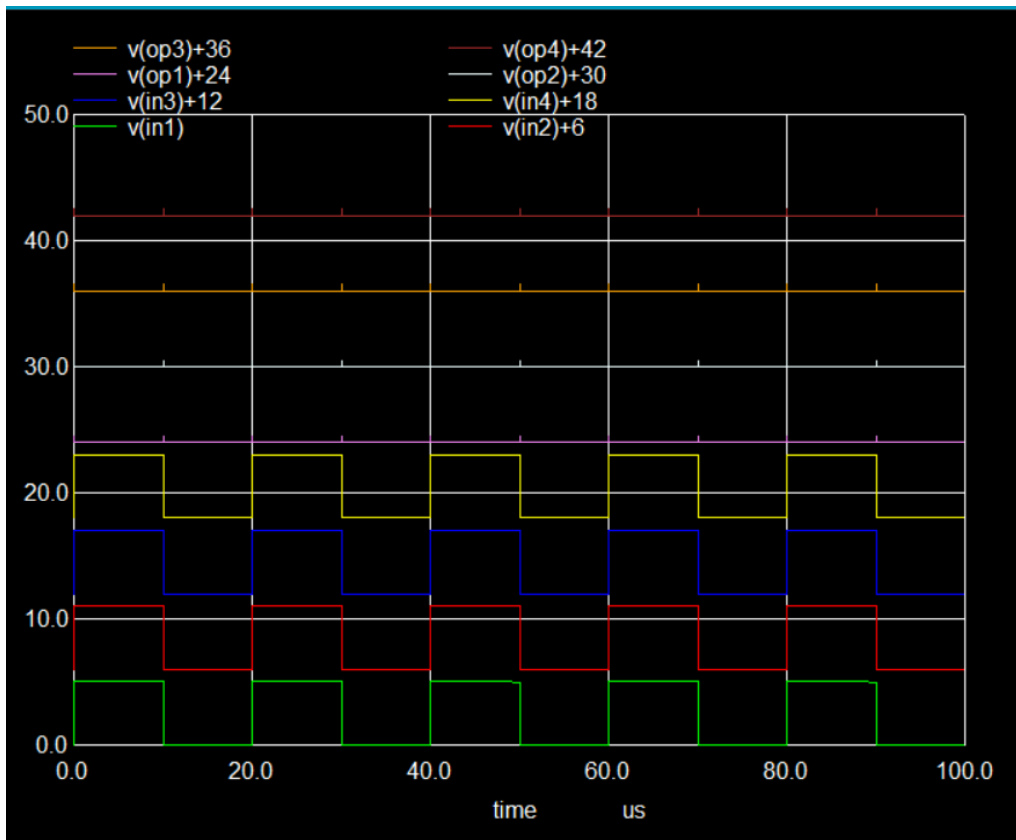

Figure 4.24: Waveform Output of SNx4HC86

4.7 HD74HC51 - AND-OR-INVERT Gate

The HD74HC51 is a complex logic gate IC consisting of AND, OR, and inverter logic combinations.

4.7.1 Pin Diagram

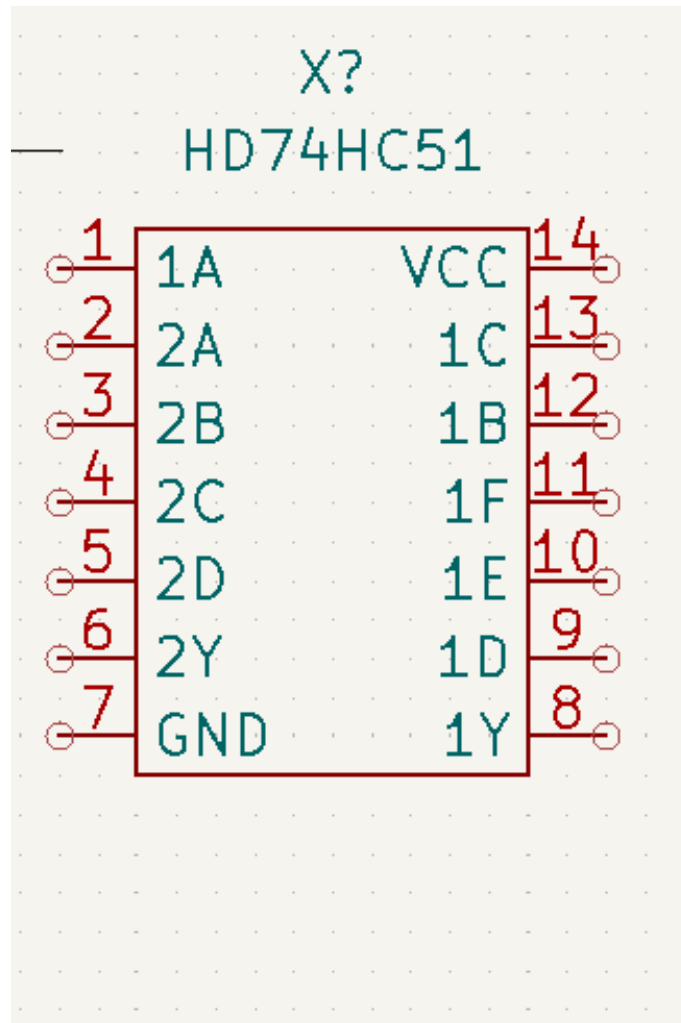

Figure 4.25: Pin Diagram of HD74HC51

4.7.2 Subcircuit Schematic Diagram

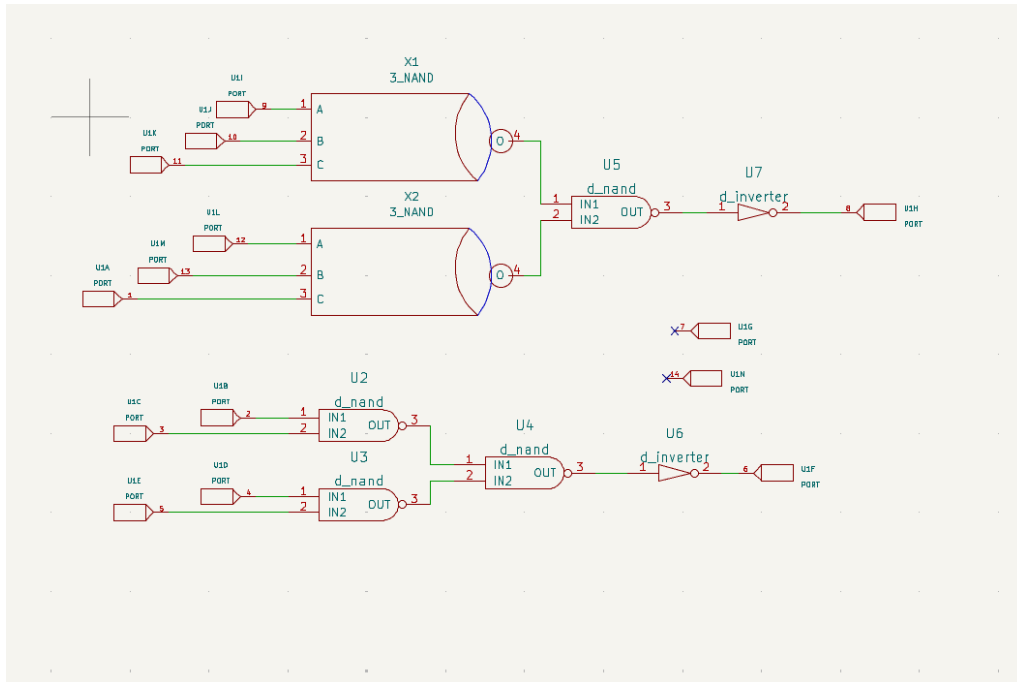

Figure 4.26: Subcircuit Schematic of HD74HC51

4.7.3 Test Circuit

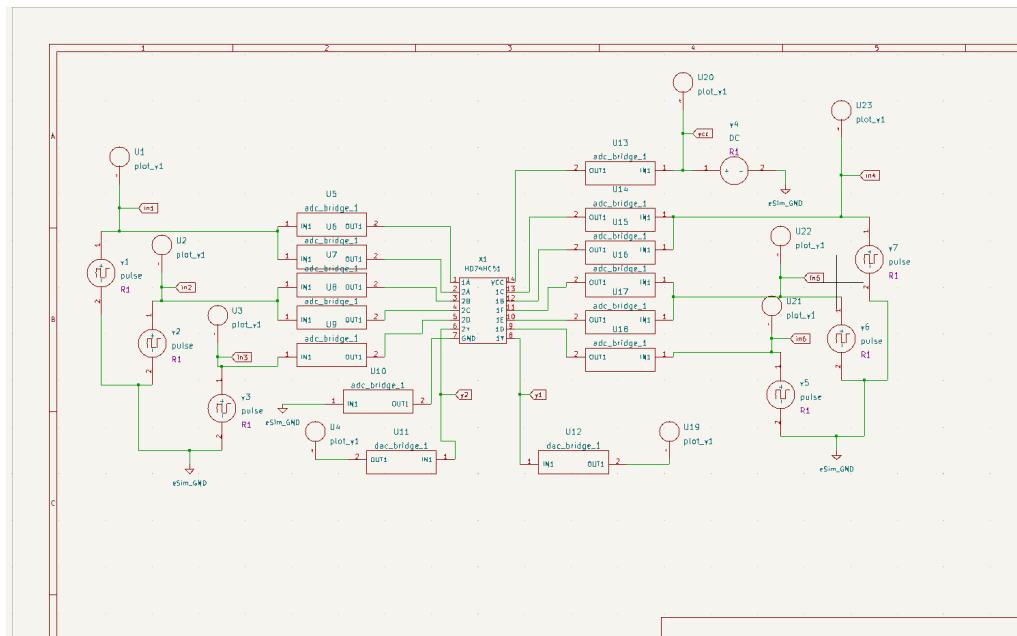

Figure 4.27: Test Circuit of HD74HC51

4.7.4 Waveforms

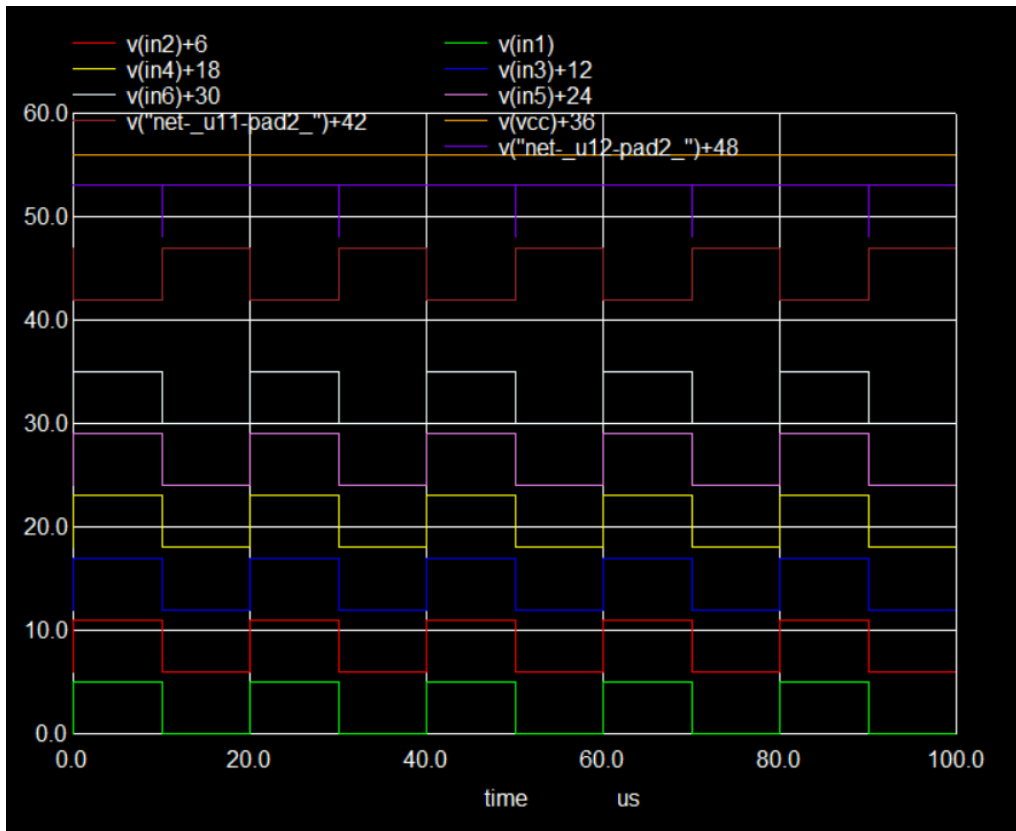

Figure 4.28: Waveform Output of HD74HC51

Chapter 5

Conclusion and Future Scope

This internship provided practical knowledge of open-source EDA tools and digital IC design using eSim. During the internship, various digital ICs such as SN74HC158, SN74LS139, MM74HC133, SNx4HC10, 74HCT280, SNx4HC86, and HD74HC51 were successfully designed and tested using the subcircuit feature of eSim. The ICs were verified using suitable test circuits and Ngspice simulations according to their datasheets and truth tables. This internship helped in improving understanding of digital electronics, schematic design, waveform analysis, and circuit simulation using tools like eSim, KiCad, Ngspice, and GHDL. It also provided hands-on experience in digital IC modeling and simulation workflows. In future, more advanced digital ICs and reusable subcircuits can be developed and integrated into the eSim library for educational and research purposes.

Chapter 6

References

1. Texas Instruments, “SN74HC158 Datasheet”
<https://www.ti.com/lit/ds/symlink/sn74hc158.pdf>
2. Texas Instruments, “SN74LS139 Datasheet”
<https://www.ti.com/lit/ds/symlink/sn74ls139.pdf>
3. ON Semiconductor, “MM74HC133 Datasheet”
<https://www.onsemi.com/pdf/datasheet/mm74hc133-d.pdf>
4. NXP Semiconductors, “74HC10 Datasheet”
https://assets.nexperia.com/documents/data-sheet/74HC_HCT10.pdf
5. Texas Instruments, “74HCT280 Datasheet”
<https://www.ti.com/lit/ds/symlink/cd74hct280.pdf>
6. NXP Semiconductors, “74HC86 Datasheet”
https://assets.nexperia.com/documents/data-sheet/74HC_HCT86.pdf
7. Renesas Electronics, “HD74HC51 Datasheet”
<https://www.renesas.com/us/en/document/dst/hd74hc51-datasheet>
8. eSim Official Documentation
<https://esim.fossee.in>
9. Ngspice User Manual
<http://ngspice.sourceforge.net/docs.html>
10. KiCad Documentation
<https://docs.kicad.org>
11. GHDL Documentation
<https://ghdl.github.io/ghdl>