



Winter Internship Report

On

DEVICE MODELING & VERIFICATION

Submitted by

Raksha Ashokbhai Dave

M.Sc. Physics

Pandit Deendayal Energy University, Gandhinagar

Under the guidance of

Prof. Prabhu Ramachandran

Department of aerospace engineering

Indian Institute of Technology Bombay

January 10, 2026

Acknowledgement

I would like to express my deepest gratitude to **Prof. Prabhu Ramachandran** for providing me the opportunity to be a part of the FOSSEE internship program and for supporting open-source engineering tool development at IIT Bombay. His guidance and vision have encouraged students and researchers to actively contribute to the open-source ecosystem.

I would also like to acknowledge **Prof. Kannan M. Moudgalya** for his foundational role in establishing and nurturing the FOSSEE initiative. His contributions toward open-source education and the creation of the FOSSEE fellowship framework have directly shaped the platform through which this internship was undertaken.

My sincere appreciation extends to my mentor, **Mr. Sumanto Kar**, for his continual support, technical guidance, and encouragement throughout the duration of this project. His insights and feedback played a key role in refining ideas, overcoming challenges, and ensuring timely completion of the tasks assigned to me.

I would also like to thank my internal mentors, **Mr. Varad Patil**, **Ms. Shanthi Priya K**, and **Mr. Aditya M**, for their valuable guidance, coordination, and technical inputs during the internship. Their mentorship contributed significantly to the clarity, progress, and successful execution of the work.

This internship has been an enriching learning experience, allowing me to work closely with open-source EDA tools, develop IC sub-circuits in eSim, and gain exposure to real-world circuit modeling and simulation workflows. The knowledge acquired during this period will undoubtedly support my future academic and professional pursuits.

I also thank the entire FOSSEE team for their coordination, assistance, and timely interactions at various stages of this work. Their collective efforts ensured smooth workflow, resource accessibility, and effective project execution.

Finally, I would like to express my heartfelt gratitude to **Pandit Deendayal Energy University (PDEU)** for providing the academic foundation, institutional support, and encouragement that enabled me to undertake and successfully complete this internship.

INDEX

What is DEVICE MODELING?	3
Parameters of Diode	4
1. Germanium Diode 1N34A	5
Key Features of 1N34A Germanium Diode	5
Pin Model	5
Result	6
Conclusion	7
2. Germanium Diode 1N34	8
Characteristics	8
Result	8
3. Germanium Diode 1N60	10
Characteristics	10
Results	10
4. Germanium Diode OA90	12
Characteristics	12
Results	12
5. Schottky Diode 1N5819	14
Characteristics	14
Pin Model	14
Results	15
Conclusion	15
6. Zener Diode D1N750	16
Characteristics	16
Pin model	16
Result	17
Reverse Bias:	18
Conclusion	18
Performance Analysis of 1N34A	19
Effect of Saturation Current (IS)	19
Effect of N - Emission Coefficient	20
Frequency Response Analysis	21
Conclusion	26
References	27

DEVICE MODELING & VERIFICATION

What is DEVICE MODELING?

Device modeling in eSim involves modifying device parameters and studying the resulting changes in circuit performance to understand and verify the behavior of electronic devices. Device modeling was performed using eSim by modifying the parameters of commonly used semiconductor devices such as diodes, BJTs, and MOSFETs. A standard germanium diode was selected here.

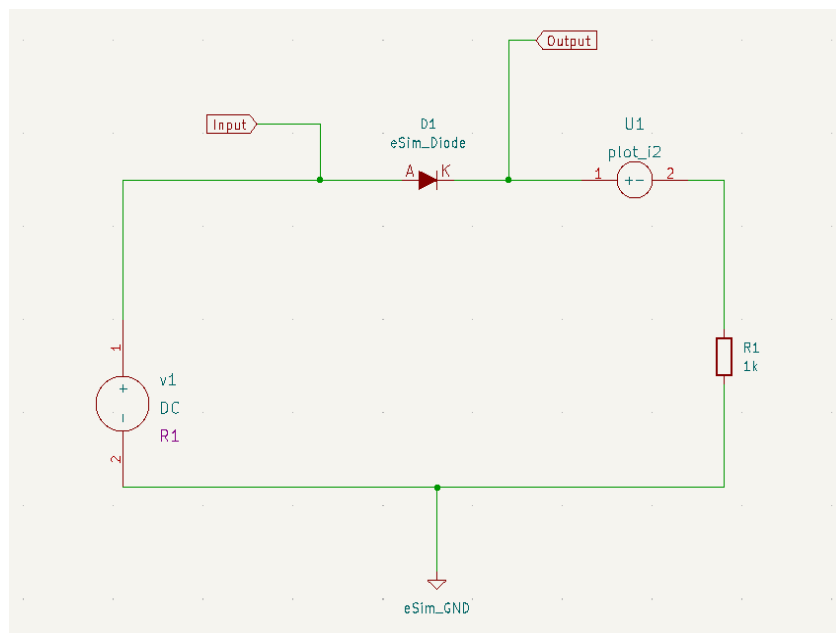

Figure 1: Schematic diagram @eSim

Parameters of Diode:

Parameter Name	Description
IBV	Reverse breakdown knee current is the amount of reverse current flowing through the diode when it reaches breakdown voltage, indicating the onset of breakdown conduction
M	The P–N junction grading coefficient defines how the junction capacitance varies with applied reverse voltage and depends on the physical doping profile of the junction.
BV	Reverse breakdown knee voltage is the voltage at which the diode begins to conduct significantly in reverse bias due to breakdown effects.
IS	Saturation current represents the small leakage current that flows through the diode even when it is reverse biased, and it strongly affects the forward I–V characteristics.
N	Emission coefficient determines how closely the diode follows the ideal diode equation and controls the slope of the exponential current–voltage curve.
TT	Transit time represents the time taken by charge carriers to cross the junction, influencing the switching speed and dynamic response of the diode.
CJO	Zero-bias junction capacitance is the capacitance of the P–N junction when no external voltage is applied, mainly affecting high-frequency behavior.
VJ	Junction potential is the built-in voltage across the P–N junction caused by the difference in charge carrier concentrations on either side of the junction.
RS	Series resistance accounts for the internal resistance of the diode due to the semiconductor material, contacts, and connecting leads.

*Each of these parameters represents a physical property of the germanium diode and together they define its static and dynamic behavior in circuit simulation.

Shockley diode equation:

$$I = I_S \left(e^{\frac{V_D}{nV_T}} - 1 \right) \quad V_T = \frac{kT}{q} \approx 26 \text{ mV at } T = 300 \text{ K}$$

- $I \rightarrow$ Diode current
- $I_S \rightarrow$ Saturation current (model parameter **IS**)
- $V_D \rightarrow$ Voltage across the diode
- $n \rightarrow$ Emission coefficient (model parameter **N**)
- $V_T \rightarrow$ Thermal voltage ($k =$ Boltzmann's constant, $T =$ temperature in Kelvin, $q =$ electron charge)

1. Germanium Diode 1N34A

Germanium Diode (1N34A):

The **1N34A** is a **commonly used germanium diode** known for its **low forward voltage drop** and high sensitivity to small signals. Unlike silicon diodes, germanium diodes conduct at much lower voltages, making them suitable for low-power and signal detection applications. Due to its well-defined electrical characteristics and availability of standard SPICE models, the 1N34A diode is widely used for device modeling and simulation studies. low knee voltage allows the diode to conduct even at small applied voltages, which makes changes in device parameters **easily noticeable in simulation**.

Key Features of 1N34A Germanium Diode:

- Semiconductor material: **Germanium**
- Low forward voltage drop: **0.2 – 0.3 V**
- Fast response to small input signals
- Suitable for **low-voltage and low-current applications**
- Clearly observable non-linear I-V characteristics

Pin Model:

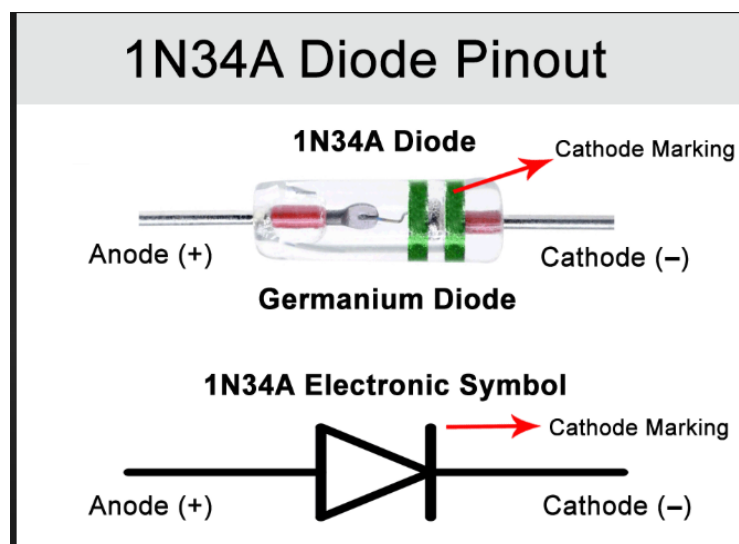

Figure 2: Pin diagram

Parameter	Value
Diode Type	Germanium (Point Contact)
IS (Saturation current)	2.0×10^{-7} A
N (Emission coefficient)	1.30
RS (Series resistance)	7 Ω
BV (Breakdown voltage)	75 V
IBV (Breakdown current)	1.8×10^{-2} A
CJO (Zero-bias junction capacitance)	0.5×10^{-12} F
VJ (Junction potential)	0.10 V
M (Grading coefficient)	0.27
TT (Transit time)	144×10^{-9} s
Source / Link	https://groups.io/g/LTspice/topic/germanium_model_for_ltspice/50240829

Result:

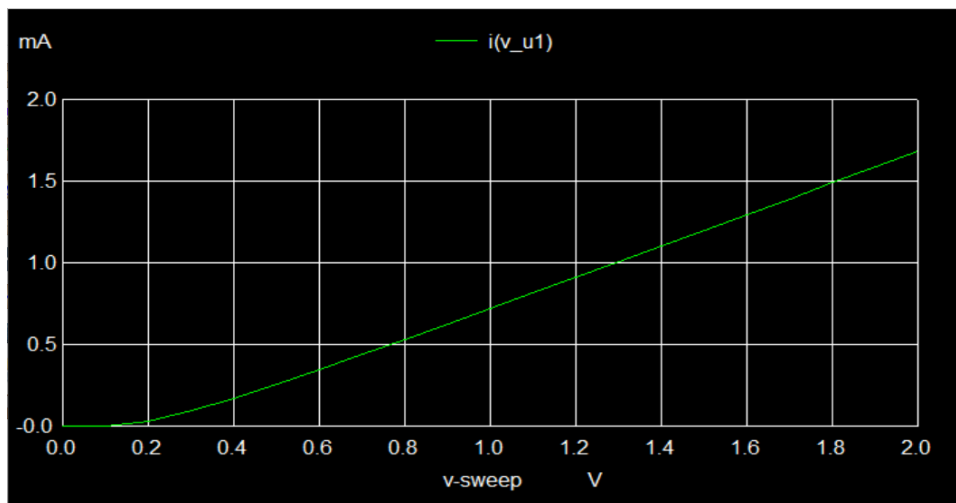

Figure 3: I-V characteristic

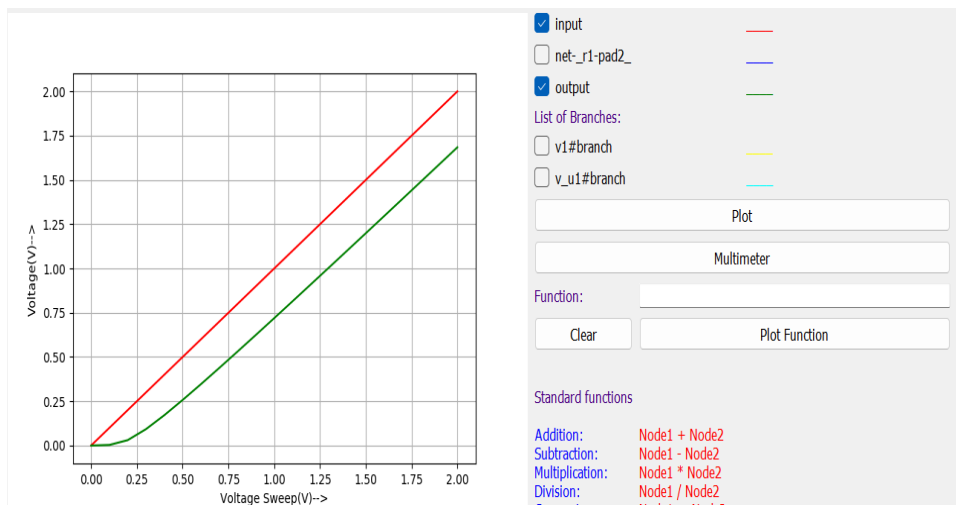

Figure 4: Python Plot

Conclusion:

The simulated I–V curve shows a low knee voltage (0.2–0.3 V) and an exponential rise in current, confirming the high saturation current of the 1N34A germanium diode. This verifies that the selected SPICE parameters correctly model the diode behavior.

2. Germanium Diode 1N34

Characteristics:

- Type: Germanium diode (similar construction to 1N34A)
- Slight variation in parameters due to manufacturing differences
- Low forward voltage drop
- Higher emission coefficient than ideal diode
- Used for signal demodulation and low-current switching

Parameter	Value
Diode Type	Germanium
IS (Saturation current)	2.0×10^{-10} A
N (Emission coefficient)	2.19
RS (Series resistance)	0.084 Ω
BV (Breakdown voltage)	60 V
IBV (Breakdown current)	1.5×10^{-5} A
CJO (Zero-bias junction capacitance)	4.82×10^{-12} F
VJ (Junction potential)	0.75 V
M (Grading coefficient)	0.333
TT (Transit time)	144×10^{-9} s
Source / Link	https://groups.io/g/LTspice/topic/spice_model_for_a_1n34_diode/50143112

Result:

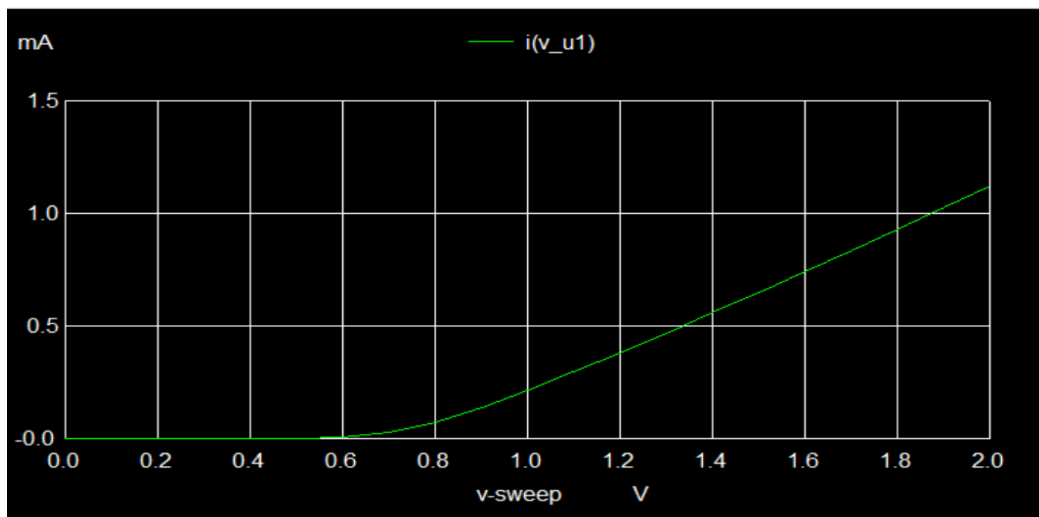

Figure 5: I V characteristics

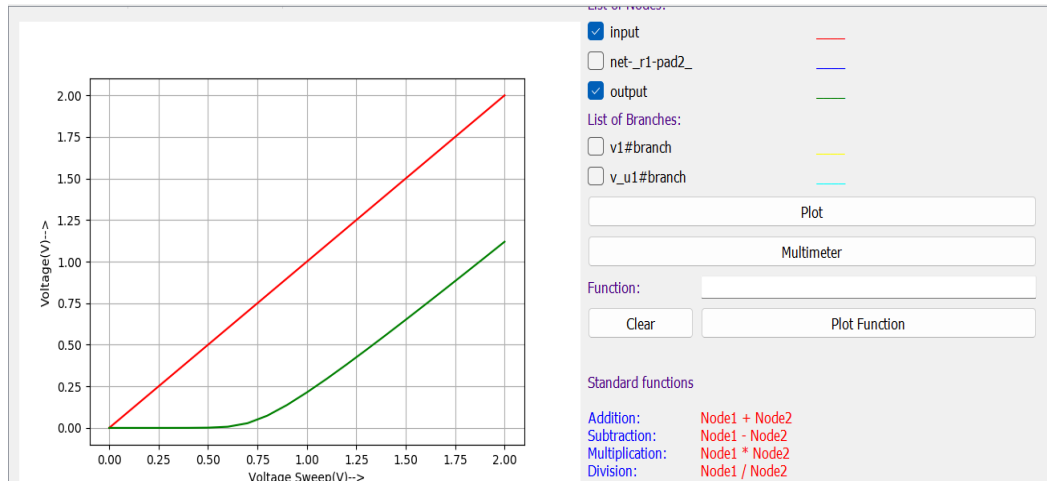

Figure 6: Python Plot

3. Germanium Diode 1N60

Characteristics:

- Type: Germanium point contact diode
- Low forward voltage but higher series resistance
- Moderate breakdown voltage
- Used in RF detectors and mixers
- Slightly slower response compared to modern silicon diodes

Parameter	Value
Diode Type	Germanium
IS (Saturation current)	1.38×10^{-6} A
N (Emission coefficient)	2.0
RS (Series resistance)	50.1 Ω
BV (Breakdown voltage)	40 V
IBV (Breakdown current)	1.0×10^{-3} A
CJO (Zero-bias junction capacitance)	1.75×10^{-12} F
VJ (Junction potential)	0.30 V
M (Grading coefficient)	0.50
TT (Transit time)	100×10^{-9} s
Source / Link	https://www.alldatasheet.com/view.jsp?Searchword=1N60%20GERMANIUM%20DIODE

Results:

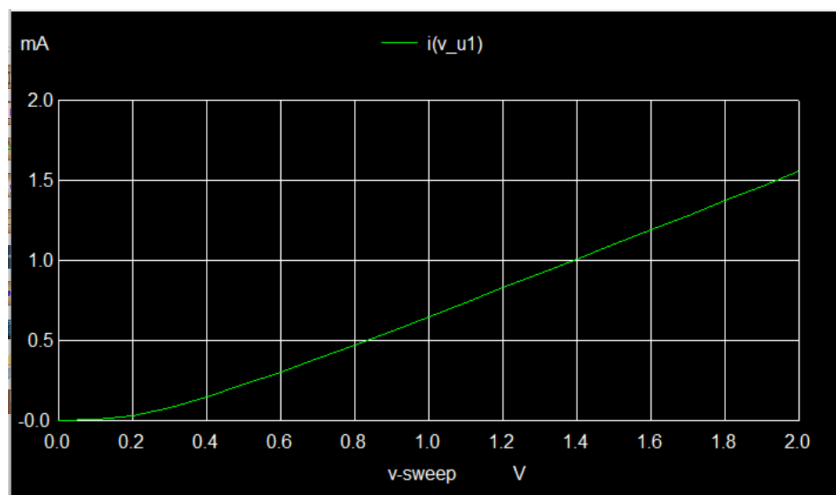

Figure 7: I-V characteristics

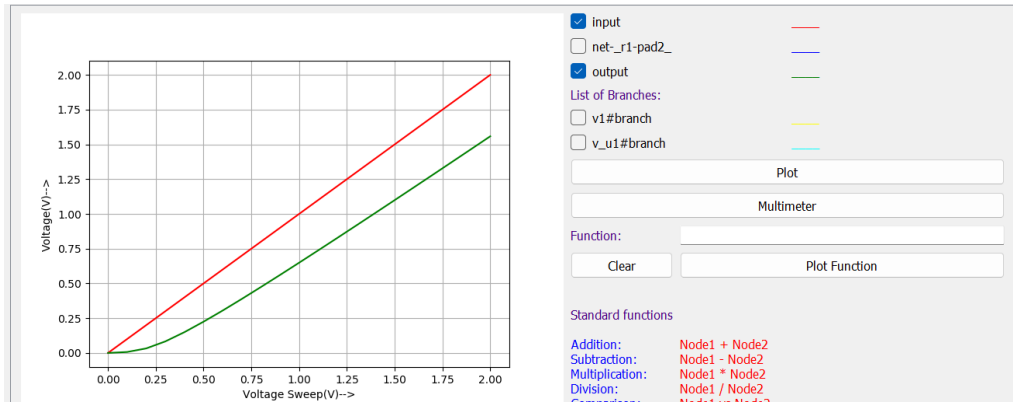

Figure 8: Python Plot

4. Germanium Diode OA90

Characteristics

- Type: Germanium point-contact diode
- Very low knee voltage (0.2 V)
- High saturation current
- Suitable for RF detection and demodulation
- Similar behavior to 1N34A with slight parameter variation

Parameter	Value
Diode Type	Germanium (Point Contact)
IS (Saturation current)	5.0×10^{-7} A
N (Emission coefficient)	1.35
RS (Series resistance)	5 Ω
BV (Breakdown voltage)	60 V
IBV (Breakdown current)	1.0×10^{-2} A
CJO (Zero-bias junction capacitance)	0.7×10^{-12} F
VJ (Junction potential)	0.15 V
M (Grading coefficient)	0.30
TT (Transit time)	150×10^{-9} s
Reference / Source	https://www.alldatasheet.com/view.jsp?Searchword=0A90%20GERMANIUM%20DIODE

Results:

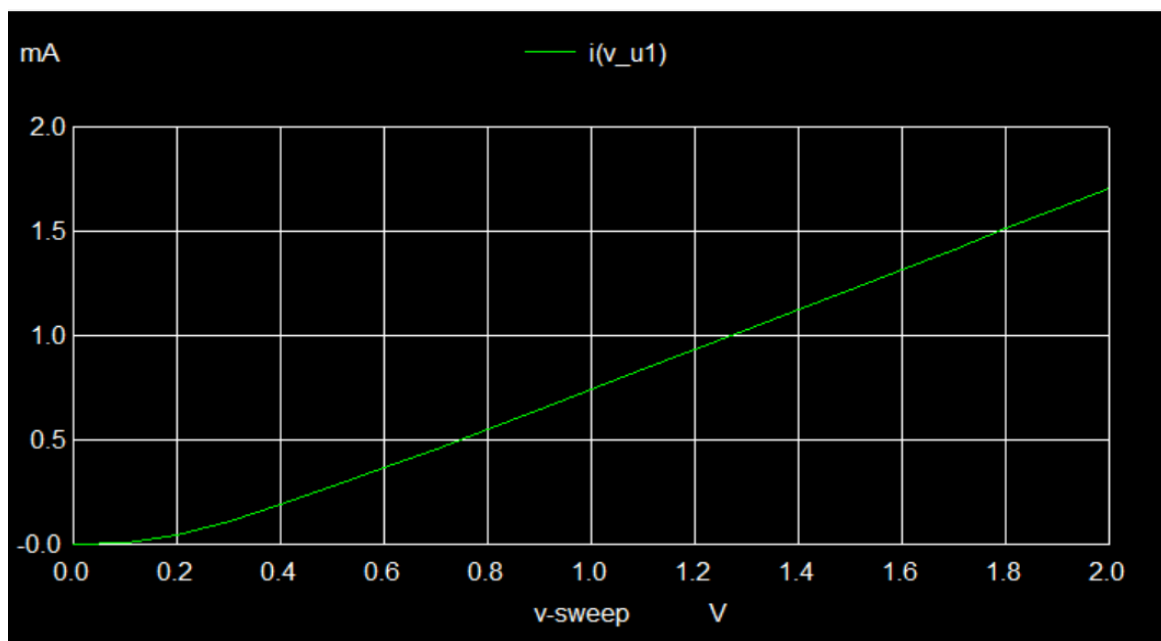

Figure 9: I-V Characteristics

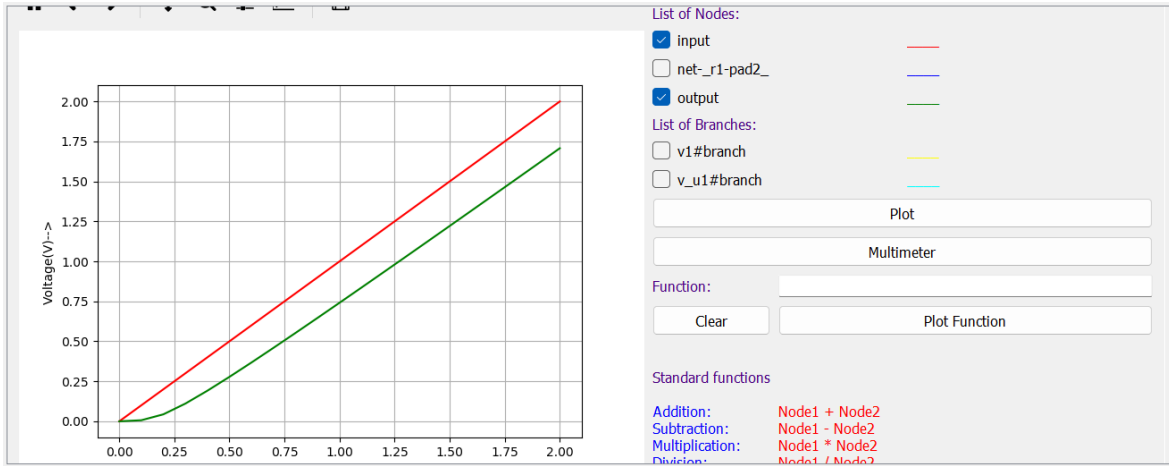

Figure 10: Python Plot

5. Schottky Diode 1N5819

The **1N5819** is a **Schottky barrier diode**, formed by a **metal–semiconductor junction** instead of a PN junction. Due to the absence of minority carrier storage, Schottky diodes exhibit **very low forward voltage drop** and **fast switching speed**, making them ideal for **power rectification and high-speed applications**.

Characteristics:

- Knee voltage: 0.2–0.3 V
- Very fast switching (small TT)
- Higher leakage current than silicon PN diodes
- Lower forward drop compared to 1N4148

Pin Model:

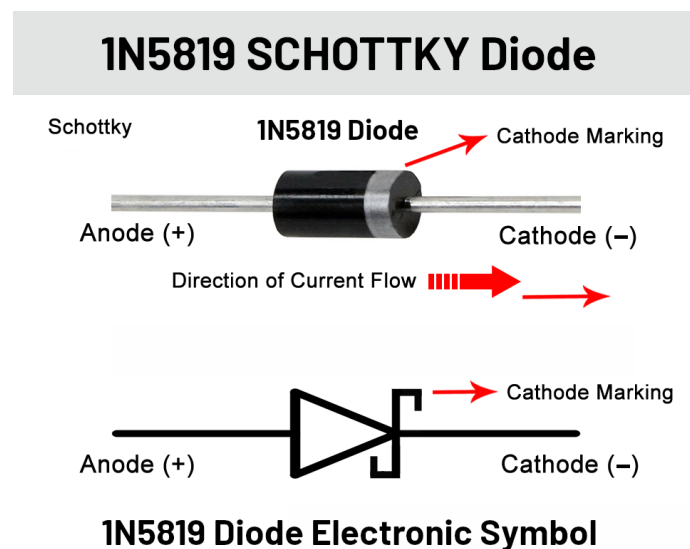

Figure 11: 1N5819 Diode

Parameter	Value
Diode Type	Schottky Barrier Diode
IS (Saturation current)	1.0×10^{-6} A
N (Emission coefficient)	1.05
RS (Series resistance)	0.04 Ω
BV (Breakdown voltage)	40 V
IBV (Breakdown current)	1.0×10^{-3} A
CJO (Zero-bias junction capacitance)	110×10^{-12} F
VJ (Junction potential)	0.20 V
M (Grading coefficient)	0.50
TT (Transit time)	5.0×10^{-9} s
Reference / Source	https://www.onsemi.com/pdf/datasheet/1n5817-d.pdf

Results:

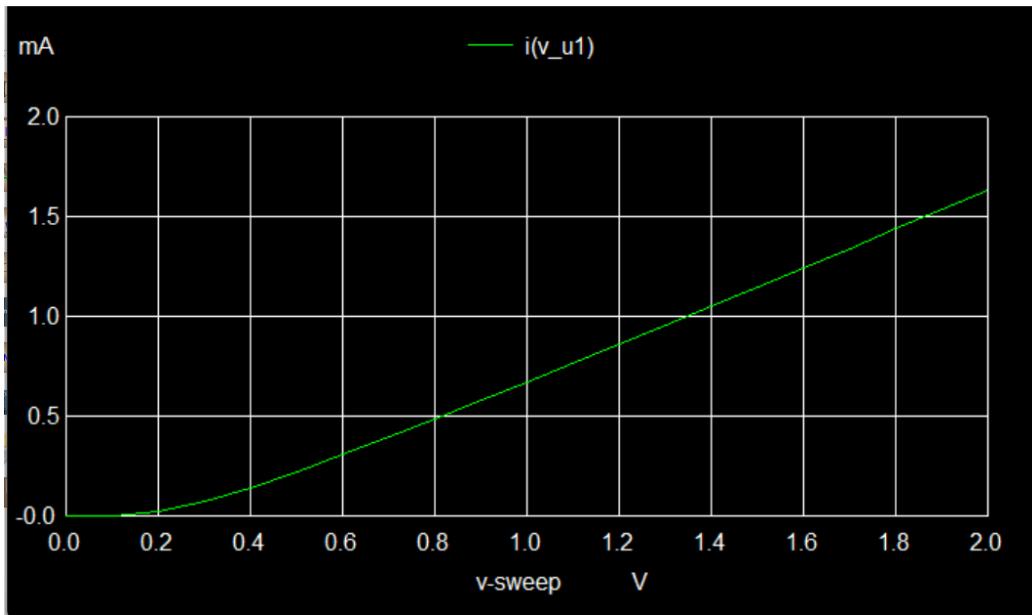

Figure 12: I-V Characteristics

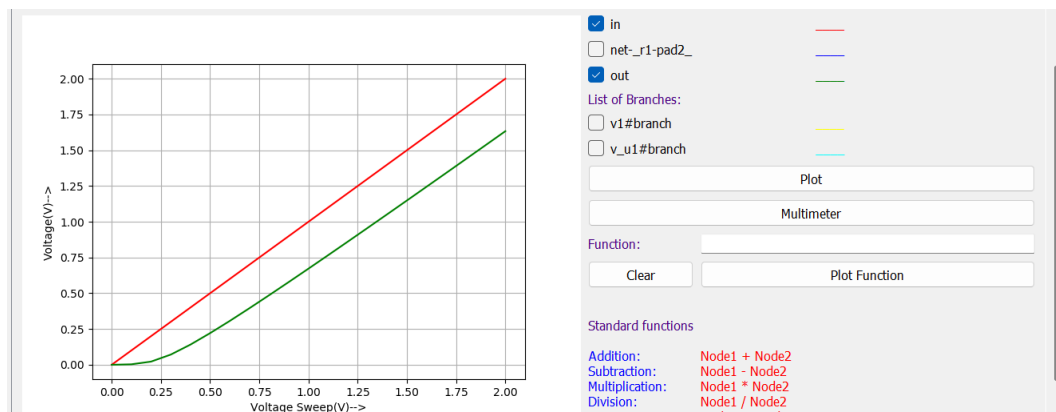

Figure 13: Python Plot

Conclusion:

The 1N5819 Schottky diode exhibits a low knee voltage (0.2–0.3 V) and fast response due to its metal–semiconductor junction, confirming the correctness of the selected SPICE parameters.

6. Zener Diode D1N750:

The 1N750 is a low-power silicon Zener diode with a nominal Zener voltage of 4.7 V. It is designed to operate in the reverse-breakdown region to provide a stable reference voltage.

Characteristics:

- Zener breakdown voltage 4.7 V in reverse bias for voltage regulation.
- Low dynamic resistance in breakdown → maintains nearly constant output voltage.
- Forward voltage 0.7 V (like a silicon diode) during normal forward conduction.
- Low leakage current before breakdown.
- Suitable for low-power reference and clamping applications.

Pin model:

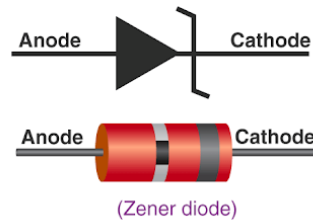

Figure 14: Zener Diode - How To Use Zener Diode

Parameter	Meaning	Value
Is	Saturation current	2.0×10^{-9} A
Rs	Series resistance	2.0 Ω
Ikf	High-level injection current	0.1 A
N	Emission coefficient	1.75
Xti	Temperature exponent for Is	3.0
Eg	Band-gap energy	1.11 eV (silicon)
Cjo	Zero-bias junction capacitance	80 pF
M	Grading coefficient	0.33
Vj	Built-in junction potential	0.75 V
Fc	Forward-bias capacitance coefficient	0.5
Nr	Reverse emission coefficient	2.0
Bv	Breakdown voltage	4.7 V
Ibv	Current at BV	5.0 mA
Nbv	Breakdown ideality factor	1.5
Ibv1	Low-current breakdown reference	0.5 mA
Nbv1	Ideality at Ibv1	2.0
Tbv1	Temperature coefficient of BV	≈ 0.002 V/K (2 mV/°C)
Isr	Reverse recombination saturation current	1.0×10^{-9} A
Reference	Datasheet / Model Source URL	Link

Result:

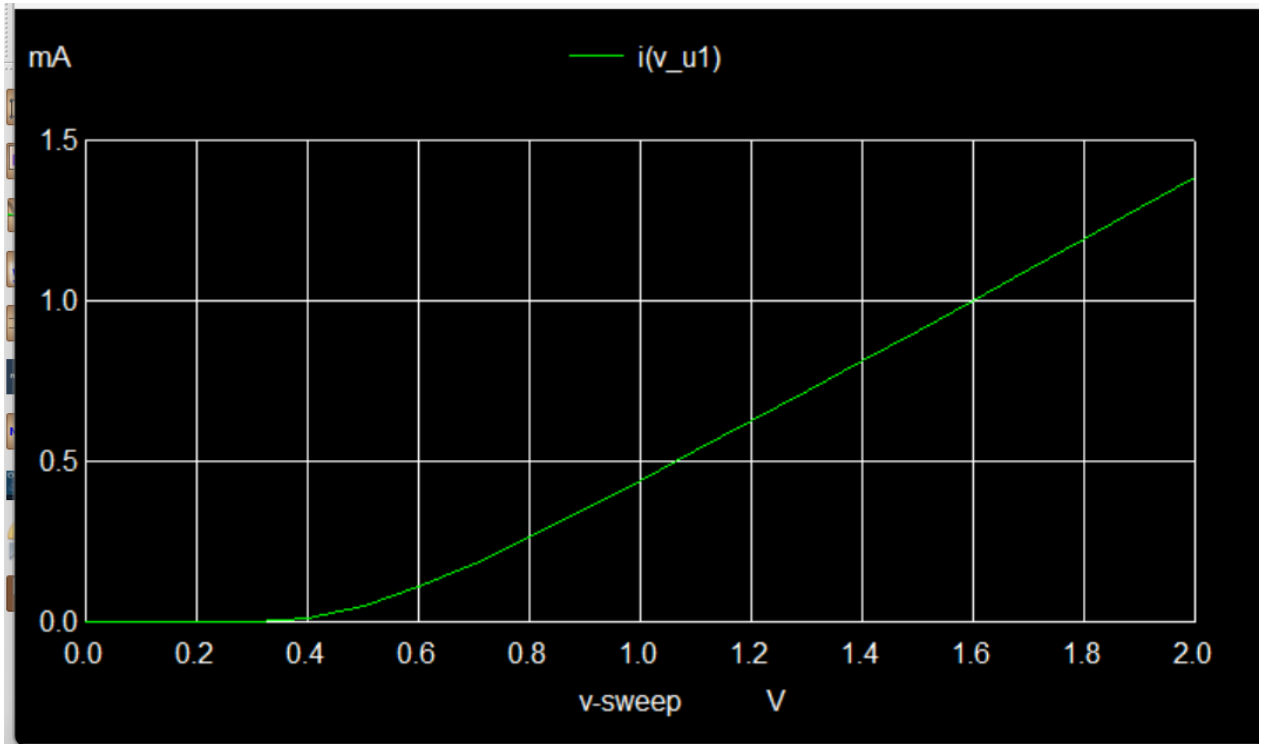

Figure 15: I-V Characteristics

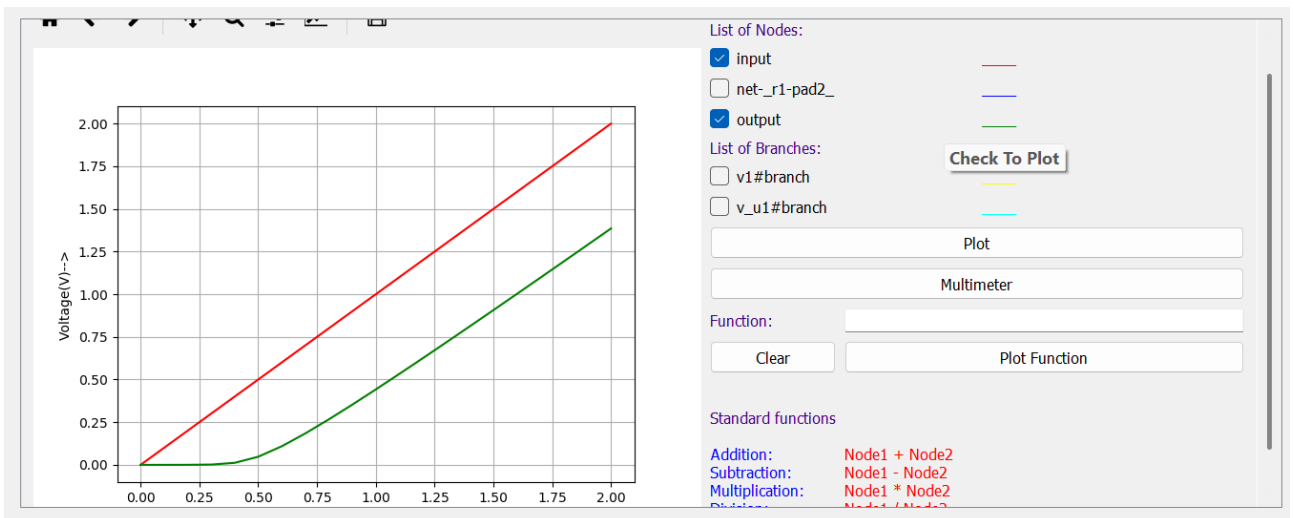
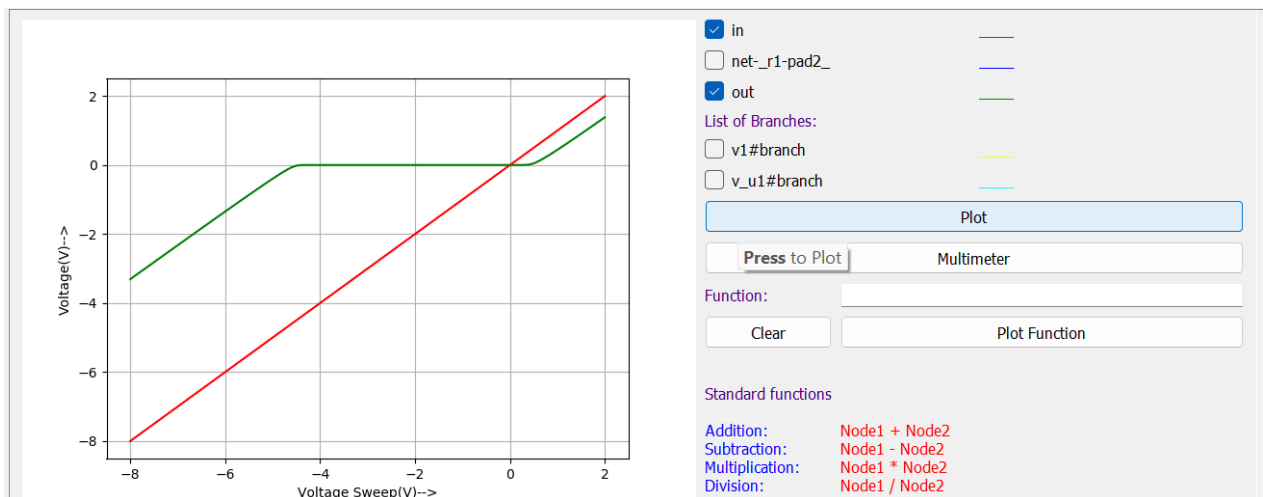
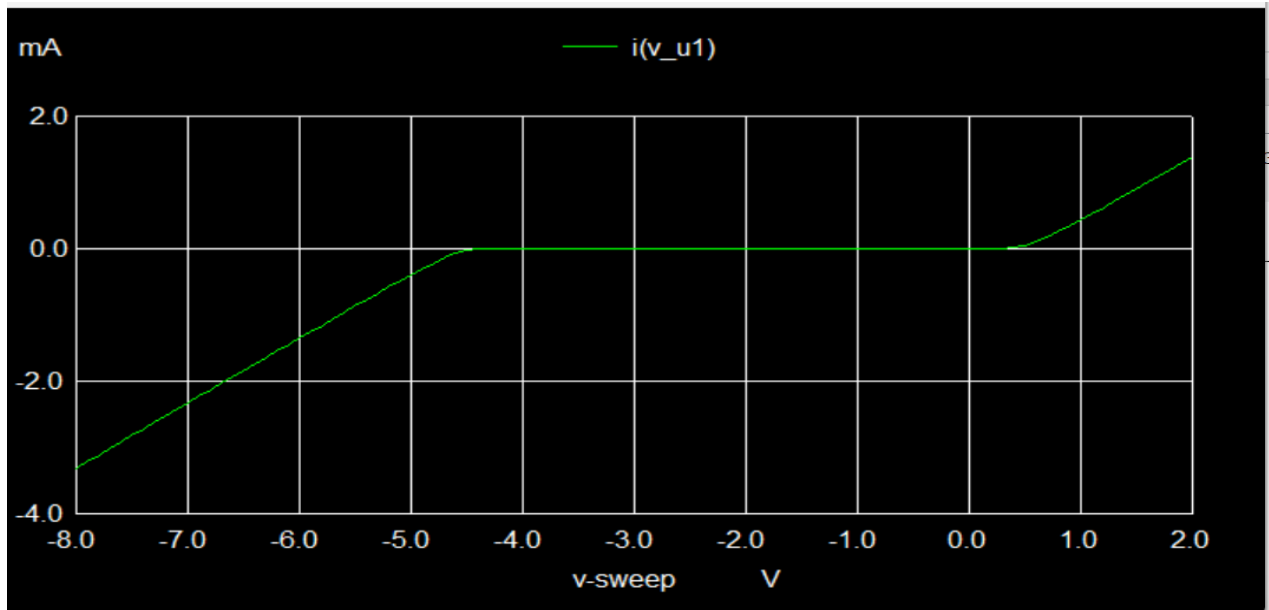

Figure 16: Python Plot

Reverse Bias:[Voltage from 0V to -8V]



Conclusion:

The reverse-bias I-V characteristic of the 1N750 Zener diode shows that the diode remains in the leakage region up to approximately -4.6 V, after which a sharp increase in current occurs, confirming the Zener breakdown voltage near 4.7 V. In forward bias, the diode conducts normally above about 0.7 V.

Performance Analysis of 1N34A Under Parameter and Thermal Variations:

1. Effect of Saturation Current (IS):

In this analysis, all diode model parameters are kept identical to the Reference Table-1 values. Only the saturation current (IS) is varied while N, RS, CJO, VJ, M, TT and BV remain constant.

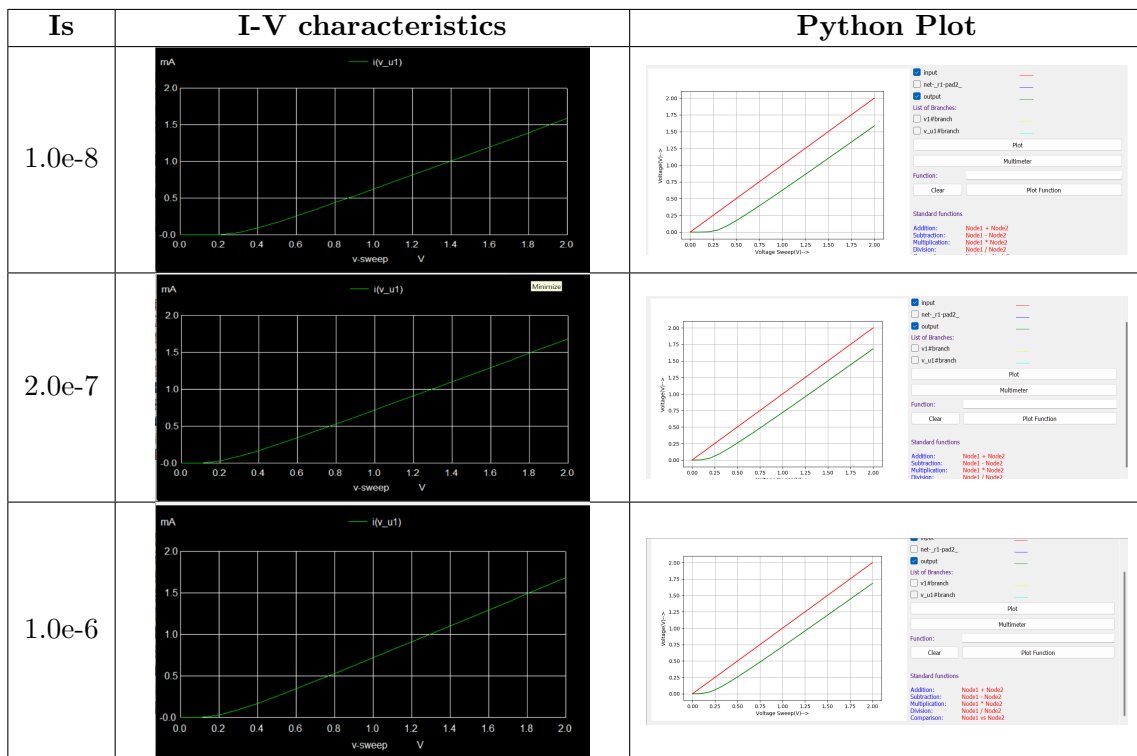

Conclusion:

Increasing the saturation current (IS) shifts the I-V curve to the left and reduces the knee voltage, increasing current for the same applied voltage in the low-conduction region.

2. Effect of N - Emission Coefficient

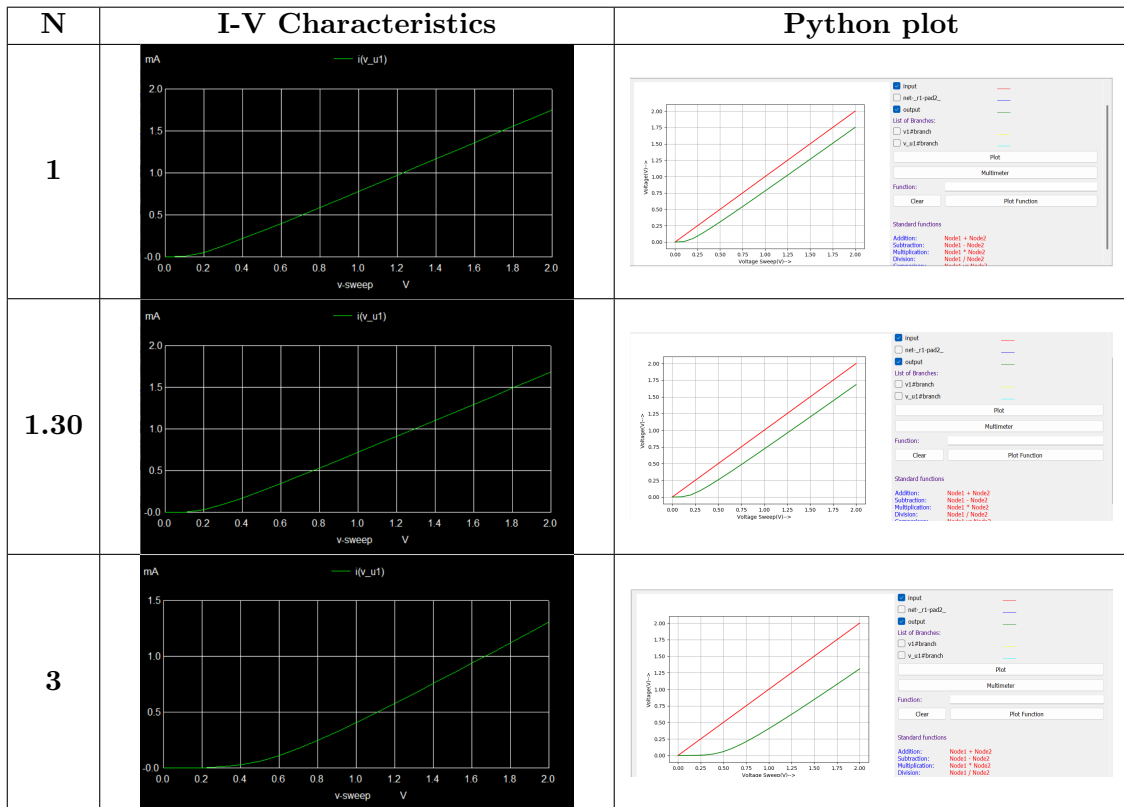

Conclusion:

A higher emission coefficient N softens the knee of the I-V curve, indicating increased recombination and non-ideal junction behavior.

Frequency Response Analysis:

The frequency response of the diode-based circuit was obtained using AC small-signal analysis by sweeping the input frequency from low to high values. The output voltage magnitude was observed as a function of frequency to study the effect of circuit elements and diode parasitic parameters on signal transmission. The response shows strong frequency dependence due to the interaction of resistive and capacitive components in the circuit.

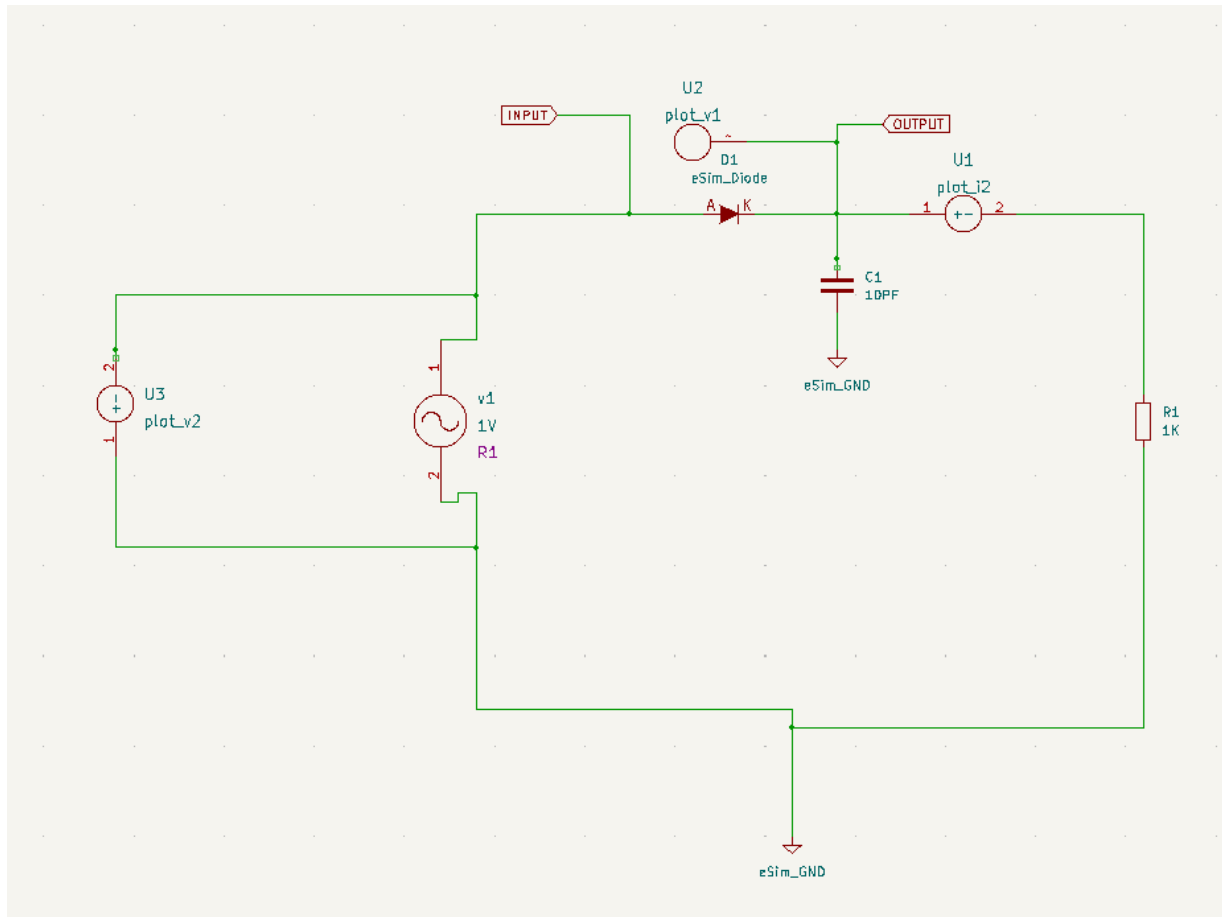

Parameters:

Netlist-frequencyresponse-78

Analysis Source Details Ngspice Model Device Modeling Subcircuits Microcontroller

Select Analysis Type

AC DC TRANSIENT

AC Analysis

Scale Lin Dec Oct

Start Frequency Hz

Stop Frequency GHz

No.of Points

Analysis Source Details Ngspice Model Device Modeling Subcircuits Microcontroller

Add parameters for ac source vv1

Enter amplitude (Volts/Amps):

Enter Phase Shift:

Spice Model Editor ✕

Passive Model **Source**

DC/AC Analysis

DC: Volts/Amps

AC magnitude: Volts/Amps AC phase: radians

Transient Analysis

Pulse Sinusoidal Exponential Piece-wise Linear FM AM Random

Initial value: Volts/Amps

Pulsed value: Volts/Amps

Delay time: seconds

Rise time: seconds

Fall time: seconds

Pulse width: seconds

Period: seconds

Source Type

Voltage Current

Disable symbol for simulation

Alternate node sequence:

Results:

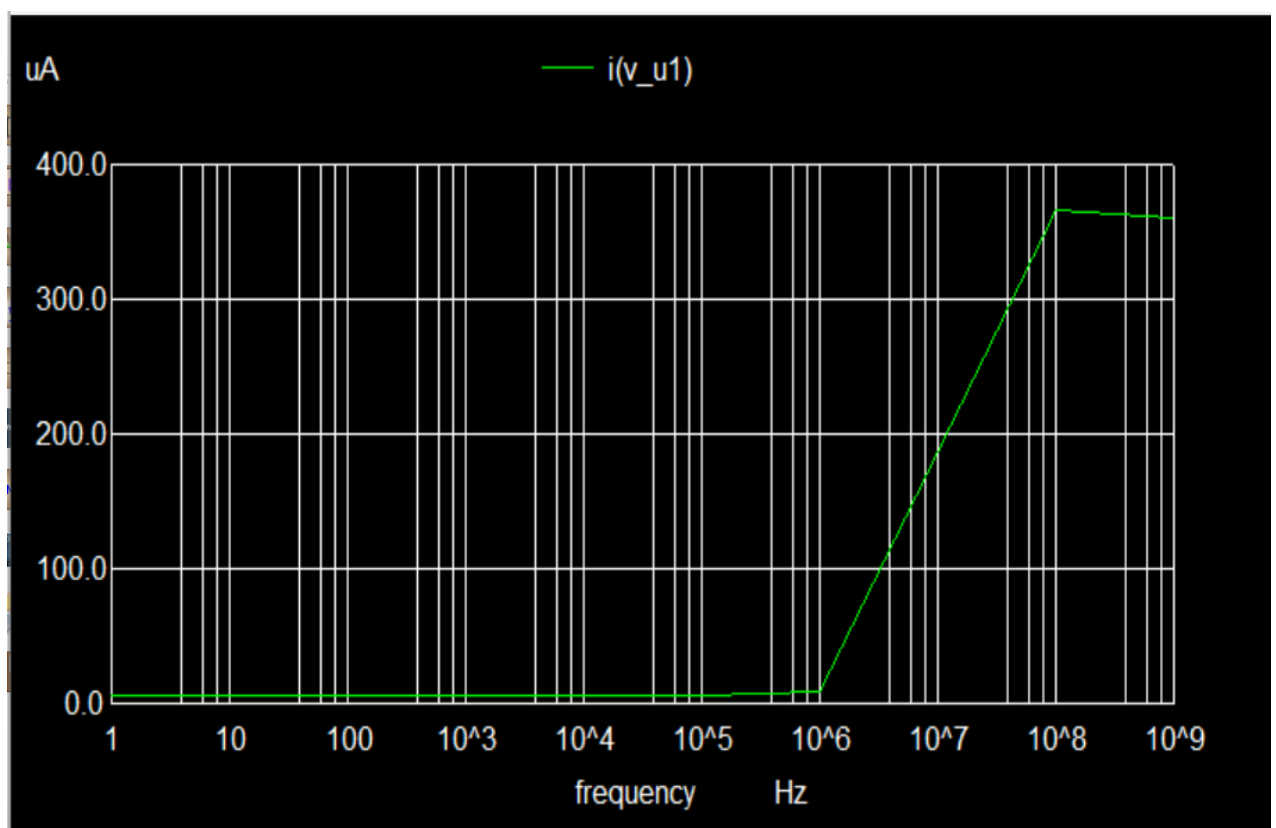
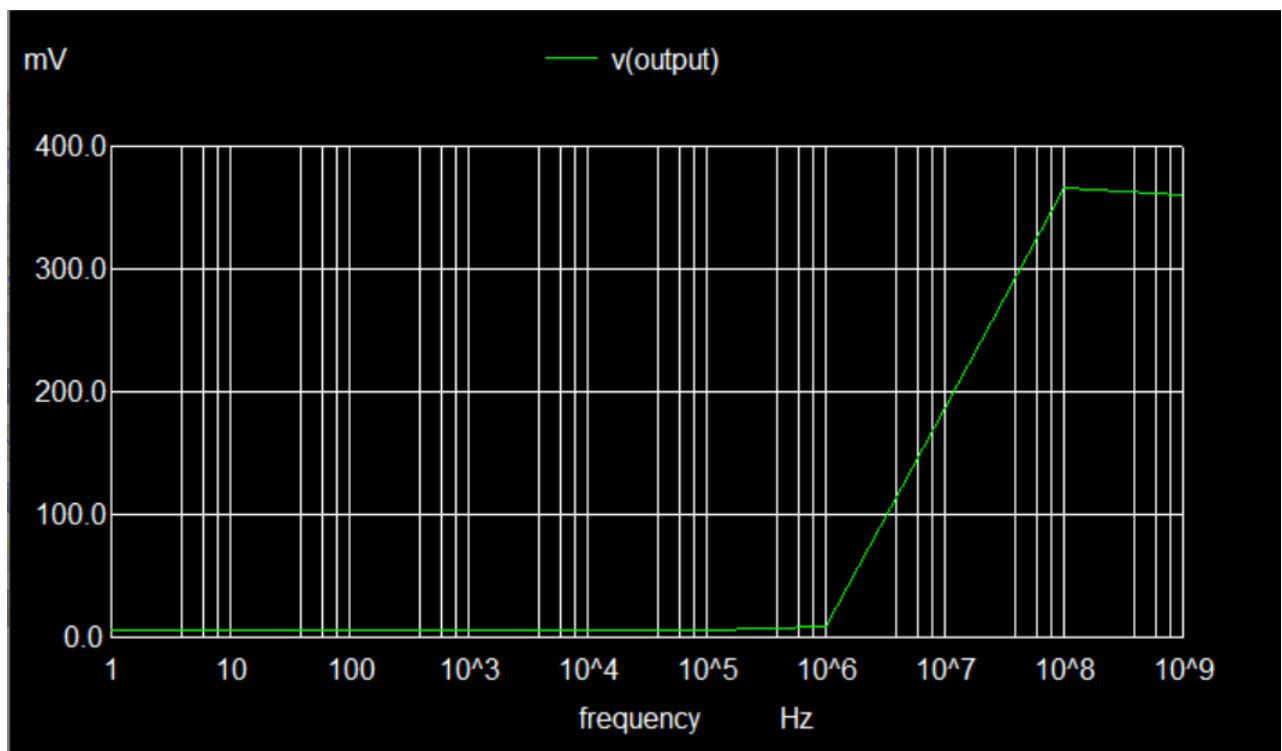

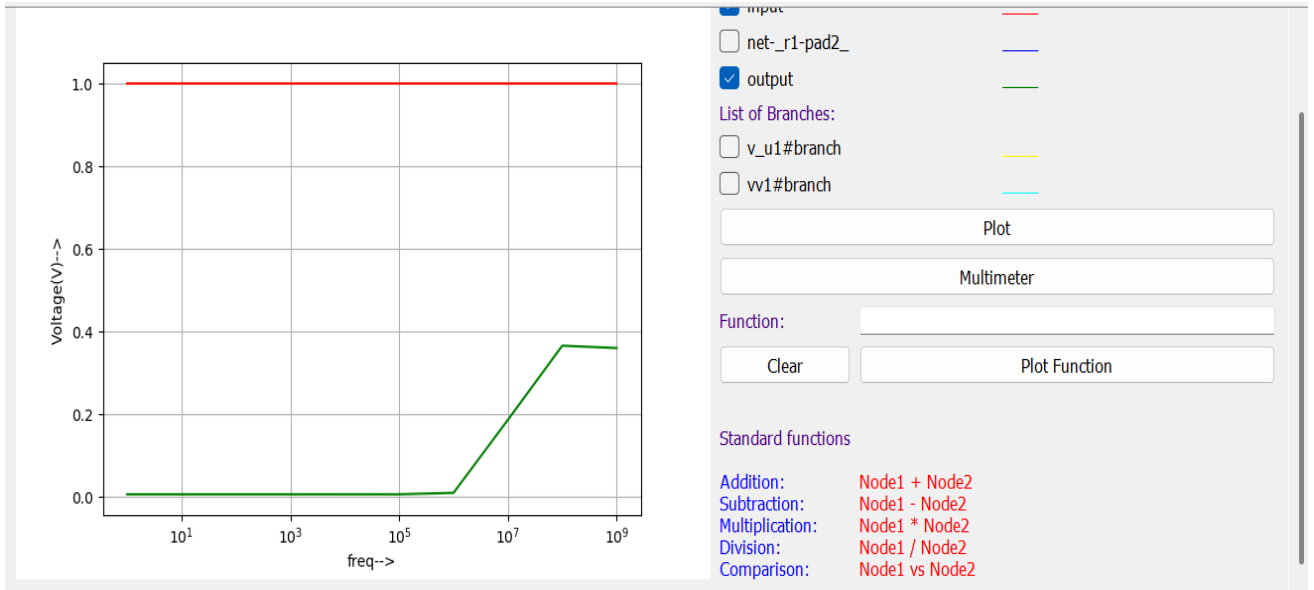

Conclusion:

The frequency response demonstrates that the diode circuit exhibits frequency-selective behavior. At lower frequencies, the output voltage remains small, while at higher frequencies the response increases and then attenuates due to capacitive and diode parasitic effects. This confirms that the diode and associated RC network significantly influence high-frequency performance.

Without Capacitor :

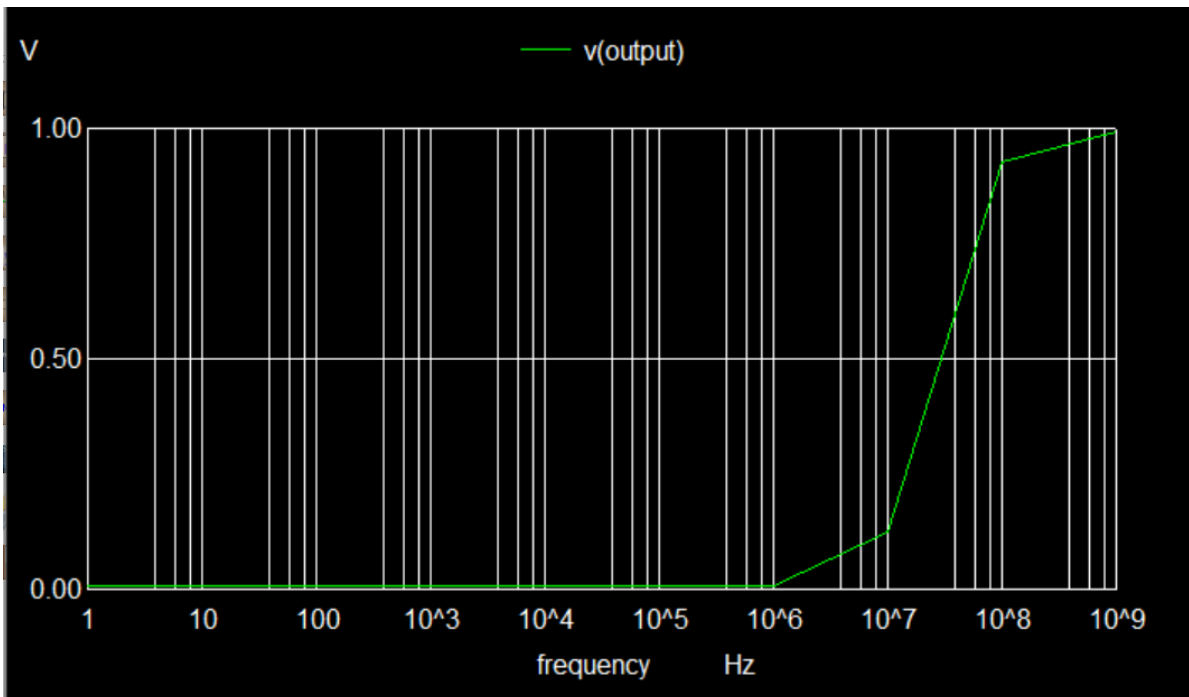

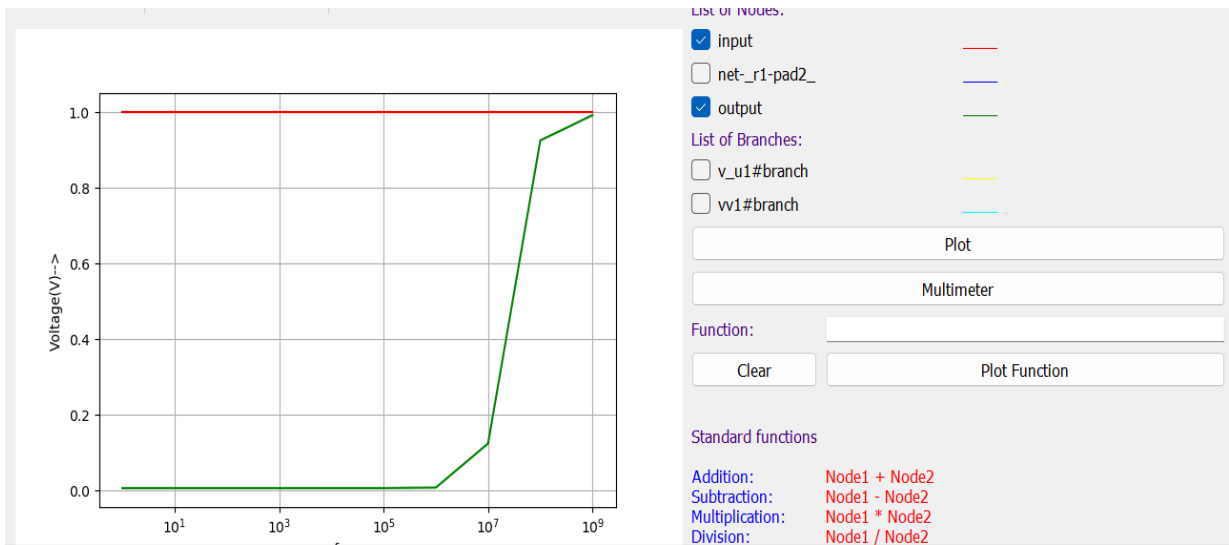
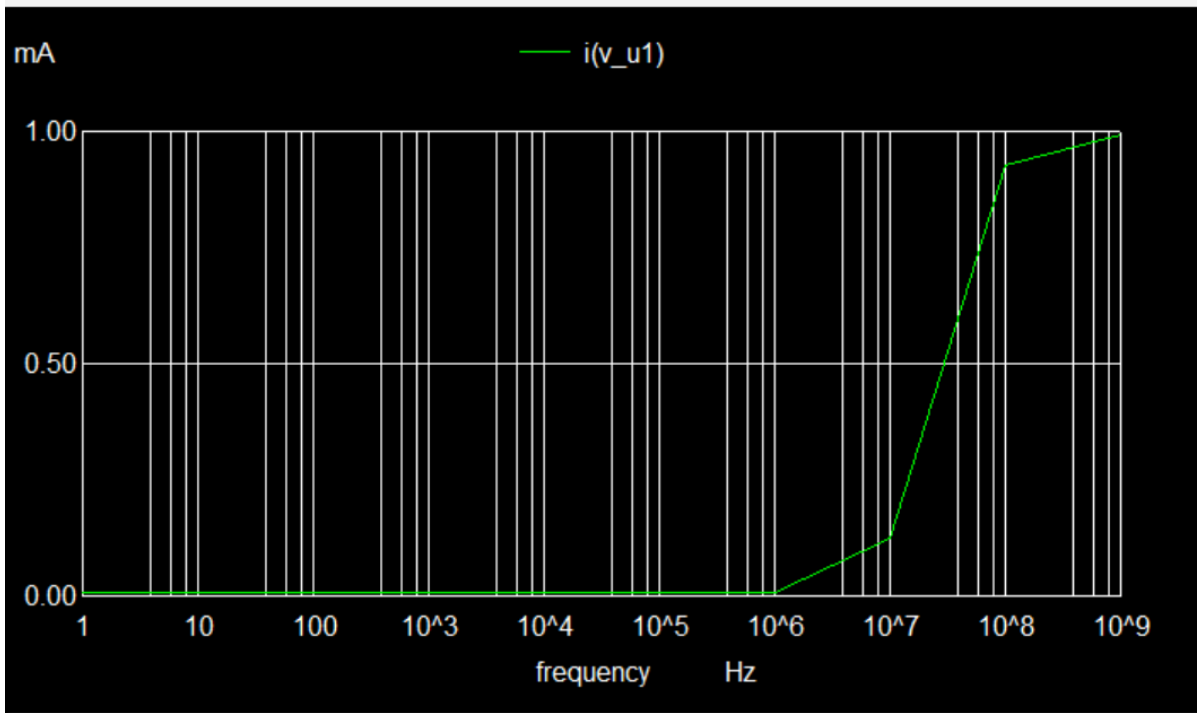

Conclusion:

Even with a germanium diode, absence of a capacitor prevents low-frequency conduction, so the output increases with frequency due to diode's dynamic conduction, giving a high-pass-like response.

References

- [1] Germanium diode model for LTspice (1N34A). *Groups.io: LTspice*. Retrieved from: https://groups.io/g/LTspice/topic/germanium_model_for_ltspice/50240829
- [2] SPICE model for 1N34 germanium diode. *Groups.io: LTspice*. Retrieved from: https://groups.io/g/LTspice/topic/spice_model_for_a_1n34_diode/50143112
- [3] 1N60 Germanium Diode Datasheet. *Alldatasheet.com*. Retrieved from: <https://www.alldatasheet.com/view.jsp?Searchword=1N60%20GERMANIUM%20DIODE>
- [4] OA90 Germanium Diode Datasheet. *Alldatasheet.com*. Retrieved from: <https://www.alldatasheet.com/view.jsp?Searchword=OA90%20GERMANIUM%20DIODE>
- [5] 1N5817-1N5819 Schottky Barrier Diode Datasheet. *ON Semiconductor*. Retrieved from: <https://www.onsemi.com/pdf/datasheet/1n5817-d.pdf>
- [6] 1N746A-1N759A Series 500 mW Zener Diodes Datasheet. *ON Semiconductor*. Retrieved from: https://www.alldatasheet.com/view.jsp?Searchword=1n750%20datasheet&gad_source=1&gad_campaignid=163996084&gbraid=0AAAAADcdDU_b-DzoB1xkq0IyyGwR-Xiqa&gclid=CjwKCAiAjojLBhAlEiwAcjhrDgT5R0pSnAkQ41YEJu3UAsL1kLYIALspIasUMiarHfkxHnRs13CJwBoC0mMQAvD_BwE
- [7] eSim - Free/Libre and Open Source EDA Tool. *FOSSEE, IIT Bombay*. Retrieved from: <https://esim.fossee.in/home>

Note: All simulations were performed using the eSim platform, an open-source EDA tool developed by FOSSEE at IIT Bombay. Device parameters were extracted from manufacturer datasheets and verified SPICE models.